

Commonwealth Avenue Replacement Over I-90 and MBTA Commuter Rail

JUSTIN PONTING Walsh Construction Company, Chicago, IL and JOSH CRAIN and DAVID ROGOWSKI, Genesis Structures Inc., Kansas City, MO

IBC 19-8

KEYWORDS: Accelerated Bridge Construction, Plate Girders, SPMT, High Skew Bridges, Design Build Project

ABSTRACT: This project replaces the existing skewed superstructure that carries Commonwealth Avenue and the MBTA Green Line B branch over I-90 (Massachusetts Turnpike) and the MBTA Commuter Rail line. Located in the center of the Boston University Campus, it serves as the main pedestrian route for students and faculty. The project used ABC methods to restore the spans in two outages a year apart. The first year, the eastbound lanes and the Green Line track spans were replaced in a 19-day outage. The second year, the westbound lanes were replaced in 15-day outage. At the end of the two years, 107 girders were replaced, and 480 pieces of precast deck slabs were set conventionally with cranes. Workers were on site 24 hours a day during the outage, with close to 250 workers per shift, more than 120,000-man hours were logged. The major challenges for this job were the time restraints working on the Mass Pike (I-90) and around the MBTA Commuter Rail schedule. This paper addresses the changes, and experienced gained, during and after the outages.

INTRODUCTION

The Commonwealth Avenue Bridge is a 398-ft plate girder bridge consisting of three bridge units each comprised of three simple spans detailed to accommodate a 60-degree skew. The bridge connects the cities of Allston, Cambridge, and Brighton and is the intersection for Commonwealth Avenue, BU Bridge Road, and Essex Street. The three bridge units carry the traffic of three lanes of eastbound Commonwealth Avenue, two lines of MBTA Green Line passenger train, and three lanes of westbound Commonwealth Avenue. Each bridge unit spans over the MBTA Commuter Rail (Span 1) and I-90 EB and I-90-WB (Spans 2-3).

Along with carrying the busy Commonwealth Avenue and Greenline traffic, the bridge serves as a popular route for pedestrians that commute and attend nearby colleges (See Photo 1). This traffic is all in addition to the I-90 traffic under the bridge which carries on average 144,000 vehicles daily.

In addition to traffic congestion and overall complexity, 5 different utilities ran through, and were supported by, the existing bridge structure. Support of the utilities complicated both the outage schedule and new structure cross-frame detailing which required unique details to accommodate each different utility type (See Photo 2).

The greatest challenge for this project was the tight timeline and pace of construction activities required during the bridge superstructure replacement outages. In 2017 during Outage 1, removal and replacement of the eastbound lanes and the Greenline Commuter rail was to be completed in 19 days. In 2018, during Outage 2, the removal and replacement of westbound lanes was to be completed in 15 days. This time frame called for strategized work planning, dry running nearly every activity, and building the bridge onsite in a laydown condition.



Photo 1 – Plan view of Intersection Between Commonwealth Avenue Bridge / I-90 / MBTA Commuter Rail

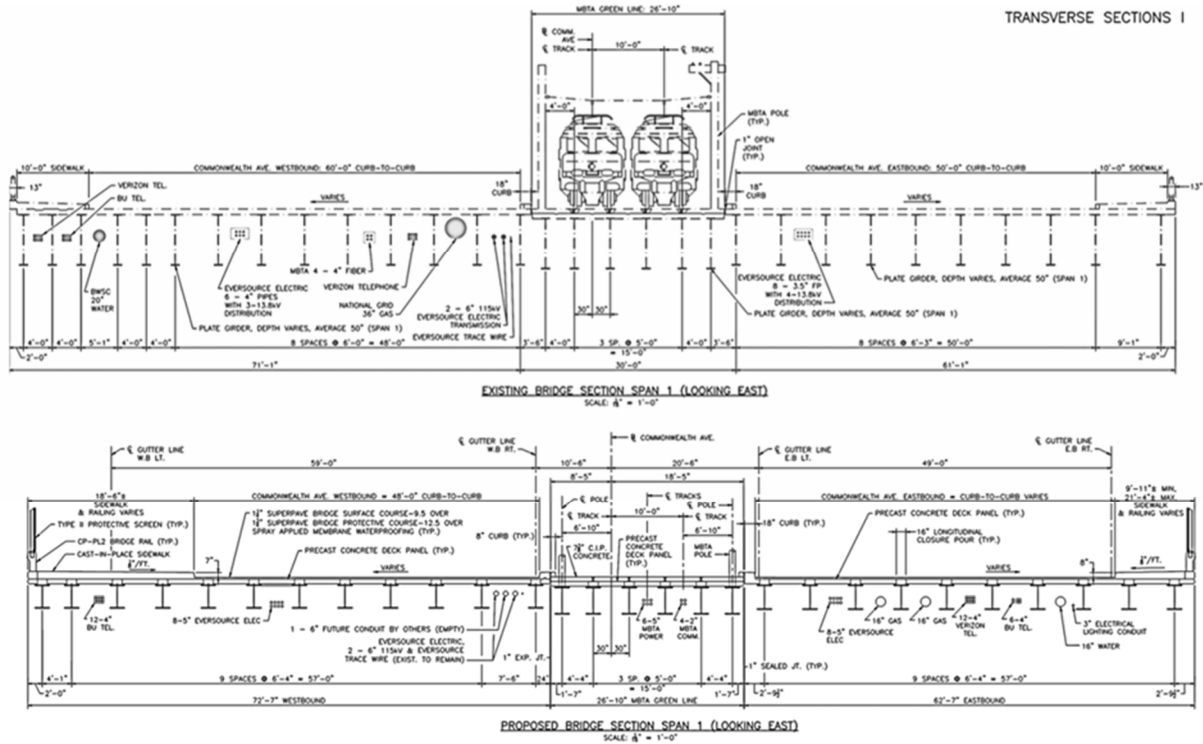

Photo 2 - Transverse section of Existing and New Superstructure

PRE-OUTAGE UTILITY WORK

The largest task prior to the outage was the utility relocations. The westbound portion of the bridge carried most of the utility lines for 5 utility corporations. Even though the switch for most of the utilities wouldn't happen until after the second phase, the work had to be done to move the lines so new roadway would not have to be disturbed. The work to move utilities began almost a year prior to the first outage and continued thru the duration between outages and finished nearly 6 months after the bridge was complete. Utility considerations dominated pre-assembly, and the outage, as tie-ins were completed.

The most challenging obstacles were 2-115kV oil cooled lines located between the westbound Commonwealth Avenue and Green Line structures. These lines could not be relocated, nor could they be de-energized. The lines had to be protected throughout all demolition operations. During the girder removal and erection, the lines had to be temporarily supported and shielded. The back walls around the line were hand demo-ed, and the backwall sections had to be cast in place during the second outage. Supporting the lines came after the first outage when the Green Line Track girders were replaced. Supports cantilevered off the girders under the bridge and vertical supports went up to carry the lines (See Photo 3)

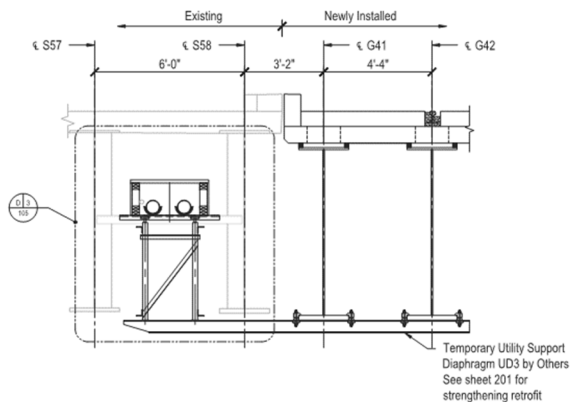

Photo 3 - Detail of Temporary KV Line Support

It was important to get the temporary support in place and to remove the existing utility brackets. This would allow the lines to be only connected to the Green line bridge and not reacting with the demolition operations performed westbound bridge.

As the supports were installed the deck above the kV lines was removed by a controlled saw cutting and slabbing operation (See Photo 4). This saved a huge amount of time during the outage and allowed the utility company to make necessary repairs to the lines prior to the outage.



Photo 4 – 115kV Temporary Supports After Deck Removal

While the work on the utilities was happening prior to the outage, the existing backwalls were pre-cut to allow for faster demolition. Precutting consisted of making vertical cuts every 7', and a horizontal cut to elevation of the new backwalls the entire length of the original backwall. Prior to the first outage, portions of the backwall were cast in place. Experience dictated that precast backwalls be used for the second outage.

PRE-OUTAGE BRIDGE CONSTRUCTION

Erection of the steel superstructure was complicated by several factors: 1) the limited time available for work during the outages; 2) the limited footprint available both down on I-90 and up on the surrounding areas of Commonwealth Avenue for equipment access; 3) the 60-degree skew; 4) the concrete deck placement was not a traditional cast-in-place, rather precast panels were used to cut down on set-up and cure time during the closure. Piers supporting Span 1 and Span 3 traveled along a parallel skew (with all girders the same length). In Span 2 the skew varied between supports (all girder lengths varied). The skew complicated not only steel fit-up and steel detailing, but also the ability of a stationary crane to be able to set all girders.

The project team concluded, the best way to ensure a smooth and efficient steel erection during the outages was to completely build out each span of the bridge prior to the outages at an offsite location (See Photo 6). Temporary concrete footings and pedestals were built at the staging yard to ensure consistency between yard elevations and elevations anticipated on the caps of the existing piers during the outages (See Photo 5).



Photo 5 - Temporary Footings and Pedestals at Staging Yard

Walsh Construction leased a pre-staging yard that was within a mile of the project, which allowed for easy access to I-90 for deliveries and for getting materials back and forth to the bridge. The on-ramps to I-90 were even within the lane closures for the outages. The time spent in the yard pre-assembling girders, laying out materials, and loading trucks led to our success.

The erection sequence for Spans 2 and 3 during the first outage entailed setting all girders as fully connected pairs. By setting the girders as pairs, time was saved since half of the cross-frames were installed and bolted ahead of the outage. The girder pairs were shown to be stable when set to support not only the self-weight of the steel and cross-frames, but also the extra weight of precast panels prior to connecting to a third girder. That fact allowed for the erection sequence to be more flexible during the outage since each stage of the sequence was in a stable configuration. Flexibility was key in the outage planning due to the multiplicity of the phases, and knowing that one task or machine sometimes gets ahead of another.

It was recognized by the project team early on that because of the high skew, detailing of cross-frames and girder fit-up would be a complex issue. For straight bridges with skewed supports, the choice of cross-frame detailing typically comes down to one of three options: 1) No Load Fit 2) Steel Dead Load Fit or 3) Total Dead Load Fit. For more detailed discussion on skewed and curved girder cross-frame detailing, reference should be made to Article 3.10 of Guidelines for Steel Girder Bridge Analysis [1] and Article 6.7.2 of the AASHTO LRFD Bridge Design Specifications [2].

The project team decided on the following fit-up option/sequence. Girder pairs would be erected in a temporary rotated total dead load fit, the precast deck was then installed over the girder pairs, followed by connection of the cross-frames between the pairs. The goal was to minimize required cross-frame installation time and effort during the outage. This complexity of the cross-frame fit was yet another reason why the project team considered pre-staging the girder erection.

In the staging yard, the girders were paired with cross-frames that were detailed to a total dead load fit which gave them a temporary rotation/twist. The precast panels were then set on top of the pairs, rotating them into the final total load configuration. Then with the deck still in place, the holes in the cross-frame connections between the pairs were field drilled to the rotated shape.

The girder installation sequence was similar for the second outage, except to simplify the rigging and installation process, the girders were all set as singles rather than in pairs. After the single girders were set, cross-frames were installed to make up the same stable girder pairs used in the first outage. Once the girder pairs were secured, the remaining sequence followed that of the first outage.

Prestaging the erection sequence allowed us to confirm and mark out pick-locations for accurate rigging of the hoisted girder centers of gravity. Each hoisted girder (single or pairs) often had unique cross-frames and flange sizes due to the varying utilities located between girders, creating unique centers of gravity for each pick during the outage.



Photo 6 – Pre-Assembled Bridge in Staging Yard

TRAFFIC CONTROL AND COORDINATION

Prior to the outages, nearly 14,000 feet of zipper wall barrier was utilized onto I-90. The barrier allowed for the crossover work to be completed, for the crane to be assembled for first outage, and for the traffic to be switched during the outages. After the first outage was complete, Walsh was able to remove the zipper wall and temporarily store it to allow for snow removal from I-90 between outages.

Commonwealth Avenue (Comm. Ave.) and Green Line traffic were completely closed for the duration the outage. Comm. Ave. vehicular traffic was detoured around the bridge and pedestrians were simply moved to the portion of the Comm. Ave. bridge not under construction. Since the Green Line was closed at the Comm. Ave. bridge, buses were used to transport Green Line passengers across the bridge on the same side used by pedestrians. Bus routes had to be mapped out and dry run to ensure public transportation would not be completely closed.

OUTAGE #1

The 2017 outage was scheduled from Wednesday, July 26th to Sunday, August 13th. During that outage, eastbound Comm. Ave. and Green Line spans were removed and replaced. Nearly half of a mile of Green Line tracks also had to be removed and replaced at the bridge approaches. Sidewalks leading up to the Comm. Ave bridge were removed

and replaced to connect to the new sidewalks on the bridge. Traffic signals, asphalt, and line striping all had to be replaced.

Prior to starting span 1, track protection under the span was installed to protect the Commuter rail. In total, 120-30ft crane mats were installed under span 1 to protect the rails of the commuter train from falling debris. Demolition took place once protection was in place.

The excavators on spans 1 and 2 took all the deck off with hydraulic hammers as they moved across the spans. Care had to be taken to protect cross-frames and diaphragms so the girders could be structurally sound to support the loads of the excavators still working on top. A total of 6 excavators worked on the two spans at the same time (See Photo 7 and Photo 8). Once all of the deck was down, cleanup of the commuter rail became a priority. The commuter rail under span 1 was required to be reopened at 12:00 a.m. the first Monday morning after the closure. All debris and

between other spans, existing girders picked out of level were a problem. After the first girder pair was hoisted, the original plan centers of gravity were verified or changed in accord with the structural elements the demolition contractor was able to remove prior to hoisting. That experience offered valuable information for pre-planning prior to the second outage.



Photo 10 - Removal of Existing Span 2 Girders as Pairs during the First Outage



Photo 11- Span 1 Girders Set as Singles

Span 1 installation of new girders was much like the removal. Girders were set as singles at the same

skew. Therefore, all three cranes used for removal were reused for setting. The girders were hoisted with the cross-frames and diaphragms attached, and with the utilities on some of the girders as well. Pre-planning really helped to speed up the erection process and the re-installation of utilities.

Span 2 installation was done in pairs like the demolition. The crawler had to walk to the south end of the bridge, lift a pair of girders off the SPMT's, lift the pair to clear the existing structure, and walk up to 140 feet to erect the pair. The new girder pairs weighed from 130kips to 182kips. The biggest challenge in erecting these girders was a space impediment discovered between the span 3 existing girders and the location of the new span 2 bearings and girders. The span 3 girders had to be blocked up at the bearings, and portions of the existing bearings, flanges, and end diaphragms had to be removed to gain sufficient clearance for installation of the span 2 pairs (See Photo 12).



Photo 12 – 400 Ton Manitowoc Crawler Crane in I-90 during the First Outage

As the girders were erected, timber shielding was installed between the bottom flanges of the girders. The shielding allowed for protection of the commuter rail trains and I-90 traffic under spans 1 and 2 once the traffic was altered for the span 3 demo/erection. Once the shielding was installed, precast deck slabs could also be set on the girders and the installation of closure forms and rebar was underway. Shielding was preinstalled in the yard between the hoisted girder pairs, allowing for half the shielding to be installed prior to the outage.

After shielding installation was completed, and all the deck panels that could be reached with the crane positioned for span 1 and span 2 operations were set, the traffic switch in I-90 commenced. The crawler crane was moved to the median and switched traffic from driving on I-90 westbound (under span 3) to driving both directions on the eastbound side (under span 2). All equipment and material were then moved to the median, or back to the yard, while traffic was switched. As soon as the traffic switch was complete, all equipment was moved onto I-90 westbound under span 3.

Because of the challenges confronted in removing and processing the pairs of girders in span 2, the project team decided that the span 3 girders would be removed as singles. That allowed us to pick up some lost time from the span 2 and 3 conflict. Girders were rigged, cut loose, and cast onto the abutment area for processing. A lot of good came out of this.

Span 3 girders were still erected as pairs with the crawler down in I-90. Since there was no crane in the abutment area for the span 3 work, having this area freed up made for a much easier erection process. The pairs were transported from the yard on SPMT's, then lifted over the abutment area, and the crawler tracked forward 100 feet. Once the girders were set, timber shielding was installed between girders to allow for precast deck setting.

To speed up installation of deck panels, it was decided during the outage to place another crane on top of Comm. Ave. westbound. The existing westbound structure had to be analyzed for the equipment load prior to implementing this decision. Placing a crane on Comm. Ave. westbound allowed for the crawler to be broken down and removed from I-90. That allowed traffic to be opened to four lanes in each direction instead of three. That decision put us a few hours ahead of schedule. On Comm. Ave., precast decking was being set and closure pours followed.

LESSON LEARNED AND NEW CHALLENGES FOR OUTAGE #2

The lessons learned between outage 1 and outage 2 are too numerous to list here, but most notably included: 1) the erection and removal of all girders

as singles; 2) the creation of better coordination between engineer and demolition contractor on what structural elements would remain prior to hoisting existing girders; 3) the use of advanced survey and geometric studies of new span 2 and existing span 3 conflict at shared pier. The second outage came with its own set of new challenges, the greatest challenges of which being the slope on I-90 under westbound Comm. Ave. Where our crane was positioned for erection and for supporting and protecting the active 115 kV lines.

I-90 has a 5-degree slope coming off of the Allston Viaduct abutment until the center of the Comm. Ave. bridge. That slope blocked the technique of using a crawler on I-90 like in the first outage.

A 600-ton hydraulic crane was used in place of the crawler to accommodate the slope. The difficulties incumbent upon using a truck crane of that size was breaking it down for moves during the demo of the girders and erection of the new girders.

Unable to pick and walk with girders during demo or erection, all girders were picked in singles. While not being able to set pairs, picking a single girder had its advantages too. Rigging was simplified, girders were easier to remove and erect, and the centers of gravity were much more accurate.

With the hydraulic cranes, the demo processing of the existing girders became more complex. The cranes had to be worked in a tight radius and could not cast the girders outside of the existing backwalls in any location to be processed. The solution was to bring in an additional SPMT used strictly for loading demo-ed girders and transporting the girders to a separate area to be processed. The processing area had a another 250-ton hydraulic crane that unloaded the girders from the SPMT. The SPMT then traveled back to the bridge so the cycle could be repeated. (See Photo 13).



Photo 13 - SMPT Loaded with Girder during Outage 2 to be Transported to Processing Location

The 115kV lines were the most nerve-racking part of the 2018 outage. The lines remained in service during the pre-outage and the outage. Girders had to be removed and erected within inches of the active lines. The protection supporting the lines was installed a month ahead of the outage. Designing the cross-frames and diaphragms around the kV's posed several challenges as well. The kV lines remained in the same place and the girder spacing was wider. Meaning the openings in the new diaphragms had to be off set, and the cross-frames had to be pieced in to avoid conflict.

The 2018 utility and backwall work was much the same as the first outage. A shoring wall was engineered and constructed using 3-ft x 3-ft x 5-ft concrete blocks to set behind the backwall. That allowed for access to remove, erect, and CIP the backwall section.

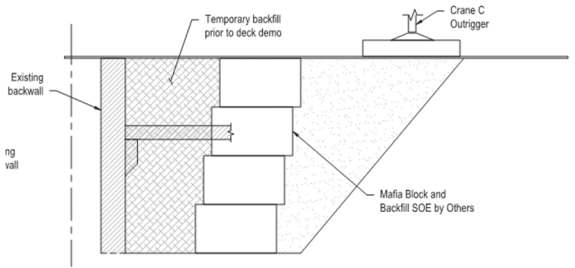

Photo 14 - Drawing of SOE Wall Near Abutments

OUTAGE #2

The 2018 outage was shorter than the first and required less work. The outage started on Thursday,

July 26th and ended Saturday August, 11th. The objective of the second outage was to replace the three westbound spans on Comm. Ave.

Comm. Ave. was closed on that Thursday night, allowing the mobilization of equipment and materials to the bridge. Excavators, cranes, trailer loads of crane mats, and girders were staged.

On Friday the 27th at 11:00 p.m., I-90 was switched to two lanes of traffic in each direction, all carried on the westbound side. The eastbound lanes were closed to allow for equipment and material to be staged.

At 1:00 a.m. on Friday the 27th the commuter rail was shutdown. And the track shielding operation to begin. Two high-rail fork lifts were used to install the mats over the top of the commuter rail tracks. A total of 70 mats were used to stretch 210 feet over the rail. All the truck loads of mats were on top of Comm. Ave. and lowered to the commuter rail directly on to the fork lifts, then carried under the bridge to be set (See Photo 15).



Photo 15 – Track Protection over MBTA Commuter Rail Line

Saturday July 28th at 7:00 a.m., the mats were completed, and the deck removal process started. Two excavators were used on span 1. They removed deck between two girders then remove the girder and carry it to the abutment area. Eight of the girders were removed in that manner. The last four girders had to be removed by the hydraulic crane on I-90 once a portion of span 2 was removed.

Three excavators operated at Span 2 to entirely remove the concrete deck. Then the 600-ton hydraulic crane was erected and picked girders one

at a time. The 60-degree skew complicated crane operations. The 600-ton crane had to work in a specific sequence to remove two girders then breakdown and reposition. Then remove three girders breakdown and reposition. Then removing the four remaining girders on span 1, and three girders from span 2 then breakdown and reposition. The last two girders in spans 1 and 2 bookended the 115kV lines. A great amount of time was spent on confirming the girder CG's to ensure a level pick while working around the kV lines. There was only one shot to get them picked correctly. (See Photo 16 and Photo 17)



Photo 16 – 600 Ton Mobile Crane in I-90 during Outage 2 Setting New Girder Around Live KV Lines



Photo 17 - New Girder Set Around Live KV Lines during Outage 2

Once the deck and girders were removed, the backwalls east of span 1 were removed. The commuter rail was cleaned up, and erection of span 1 started prior to the first train coming through.

For erection of span 1, a separate 600-ton hydraulic crane was set on the west abutment to erect nine of the 12 girders in span 1, 72 precast deck slabs, and six precast backwall panels.

The last three girders were installed with the crane on I-90. Because of the high skew, the crane positioned behind the abutment was not able to reach.

The new girders for span 1 weighed from 29 kips to 35 kips. Girders were installed as singles, but cross-frames were installed off both sides of the girders. This eliminated the need to tie down each girder, eliminated 50% of the bolts, allowed the crane time for flying each cross-frame, and allowed the utilities to ride with the girders while being erected. Shielding was installed as soon as the girders were set for the protection of the commuter rail.

As soon as the girders around the kV lines were erected, the first backwall panel was set to allow formwork and rebar to be installed around the kV lines. The CIP had to be completed so approach slabs and road work could progress.

Span 2 erection started off with the crane working from the same position that it finished the demo process. From that position, the first four new girders were erected with the first two set around the kV lines. The crane would again have to set 4-5 girders from a position then be broken down, moved, and re-erected. A total of four different positions were used for setting the new span 2 girders.

As the girders were erected, shielding was installed, and precast deck panels were set.

As soon as the erection was complete, the 600-ton crane was broken down and moved to the east abutment of Comm. Ave. That move kept the crane out of I-90 westbound for the demo and erection of span 3. In span 3 demo, shielding was still in place from the previous year. It was removed as soon as the traffic switch occurred that put all traffic on I-90's eastbound side.

been done differently, but much of the plan would have be repeated.

ACKNOWLEDGEMENTS

The authors would like to acknowledge MassDOT, City of Boston, and Boston University for the help, support, and contributions before, during and after the outages.

REFERENCES

1. American Association of State Highway Transportation Officials (AASHTO) / National Steel Bridge Alliance (NSBA) Steel Bridge Collaboration. 2014. G13.1 Guidelines for Steel Girder Bridge Analysis, 2nd Edition.
2. American Association of State Highway Transportation Officials (AASHTO). 2014 AASHTO LRFD Bridge Design Specifications, 7th Edition.