

Buck O'Neil Bridge Demolition

Zach Bardot & John Boschert, Genesis Structures

Kevin Deye, Massman Construction

Best of IBC Webinar



Project Summary

- Replace 70 year old existing bridge
- Limited time for bridge closure
- Signature arch span explosive demolition



Project Outline

- Project Introduction
- Demo Sequence
- Unit 1 Demo - TPG
- Unit 2, 3, & 4 Deck Demo
- Unit 2 & 3 Demo - Steel Plate Girder
- Unit 4 Demo - Tied Arch
- Current Status

Project Outline

- **Project Introduction**
- Demo Sequence
- Unit 1 Demo - TPG
- Unit 2, 3, & 4 Deck Demo
- Unit 2 & 3 Demo - Steel Plate Girder
- Unit 4 Demo - Tied Arch
- Current Status

Project Location

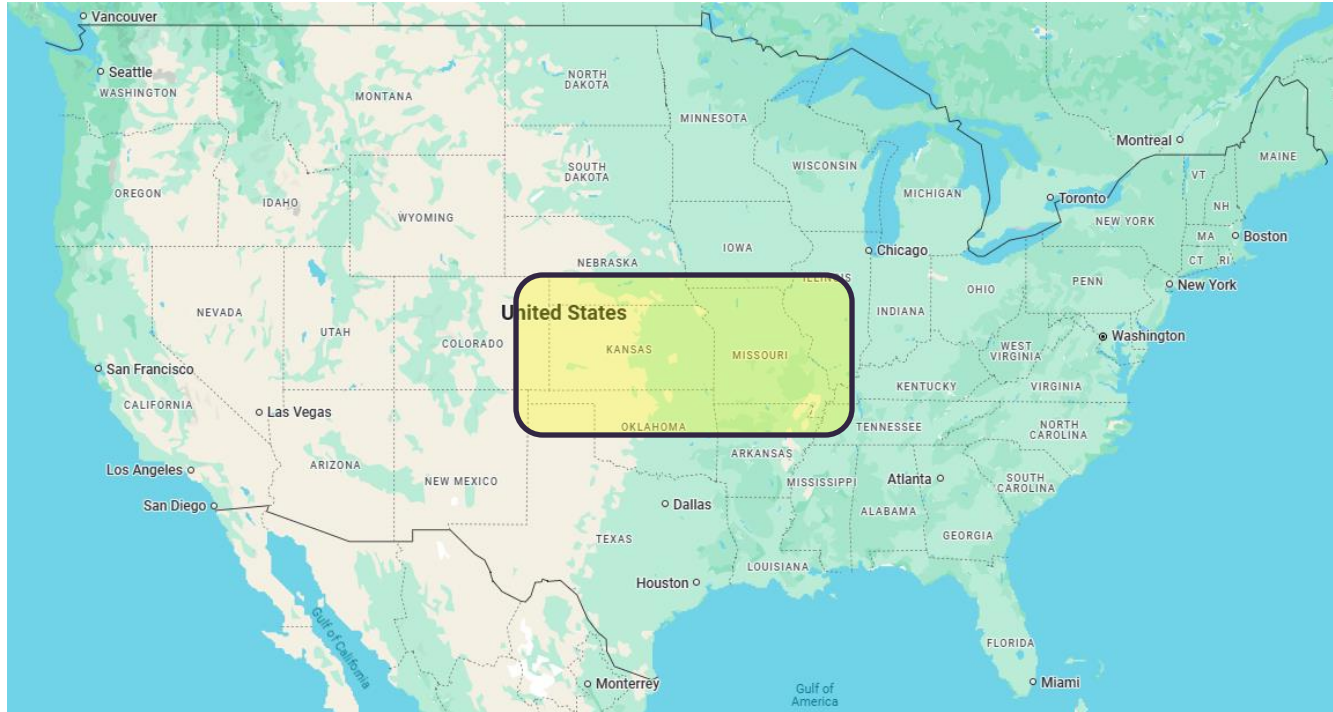

Project Location



Project Location

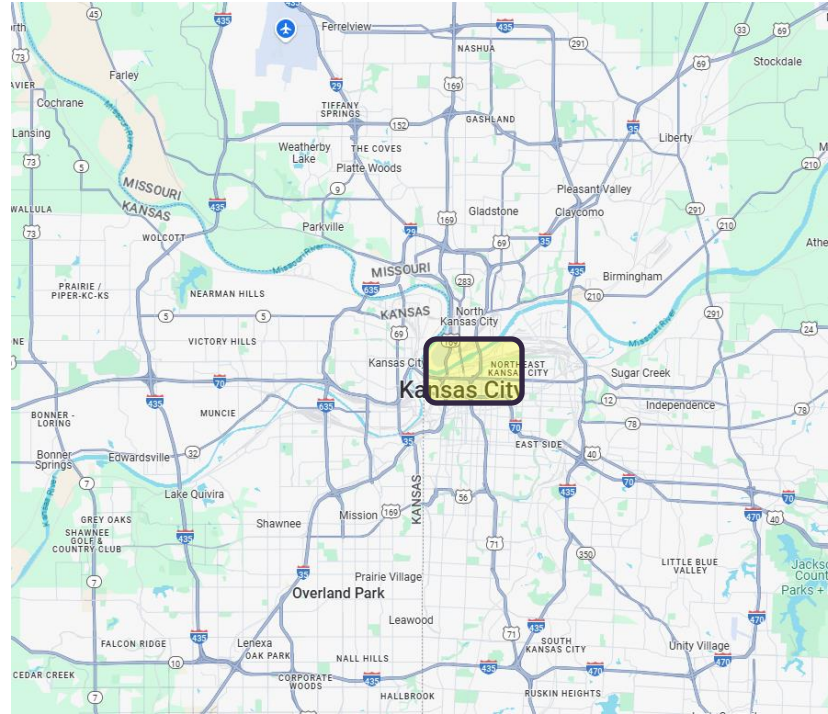

Project Location

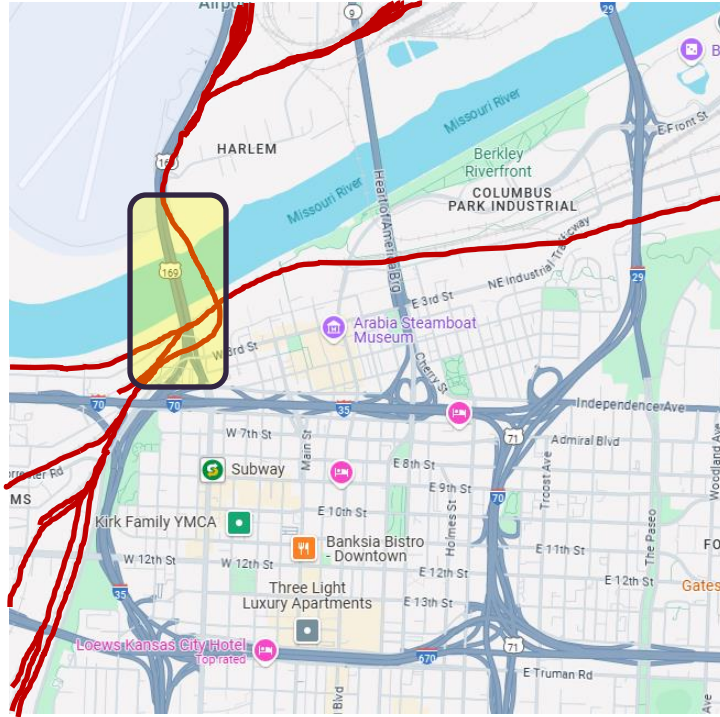

Project Team

- Owner: Missouri Department of Transportation
- Contractor: Massman / Clarkson JV
- Explosive Contractor: Veit & Co.
- Demolition Engineer: Genesis Structures



Project Timeline

- Original Bridge Constructed: 1956
- Contract Awarded: 2021
- Begin Construction: 2021
- Demo Design Plans Complete: 2023/2024
- Demo Complete: 2025

Project Scope

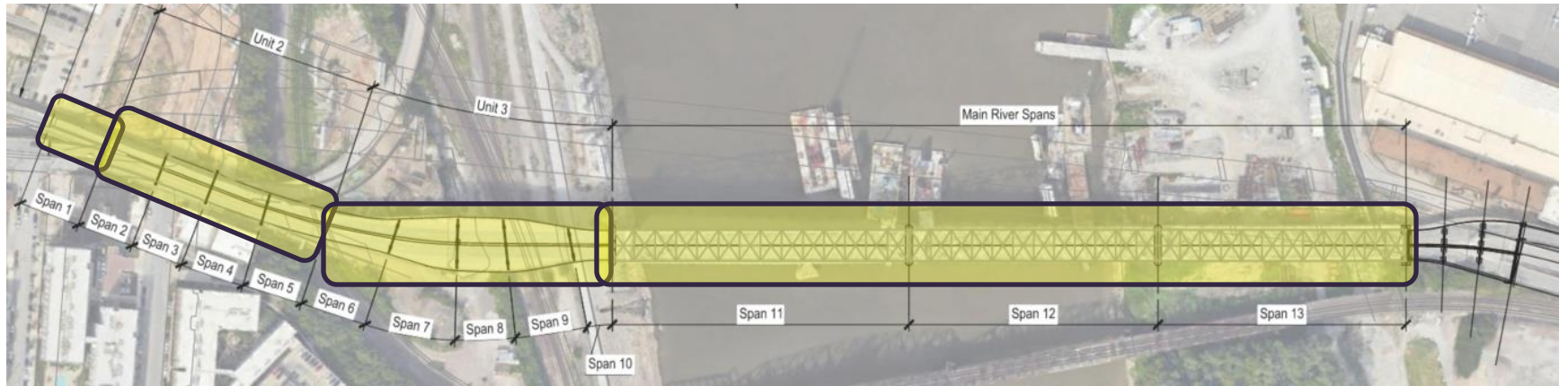

Existing Bridge – Unit 1 (TPG)



Existing Bridge – Units 2 & 3



Existing Bridge – Unit 4



Project Outline

- Project Introduction
- **Demo Sequence**
- Unit 1 Demo - TPG
- Unit 2, 3, & 4 Deck Demo
- Unit 2 & 3 Demo - Steel Plate Girder
- Unit 4 Demo - Tied Arch
- Current Status

Demolition Sequence



- TIE-IN TO EXISTING STREETS
- NORTH BOUND TRAFFIC HAD TO BE MAINTAINED
- SOUTH BOUND TRAFFIC CLOSURE FOR 616 DAYS
- RAILROADS

Demolition Sequence

Phase 0



OLD
BRIDGE

Demolition Sequence

Phase 1



Demolition Sequence

Phase 1



Demolition Sequence

Phase 2



Demolition Sequence

Phase 2



Demolition Sequence

Phase 3

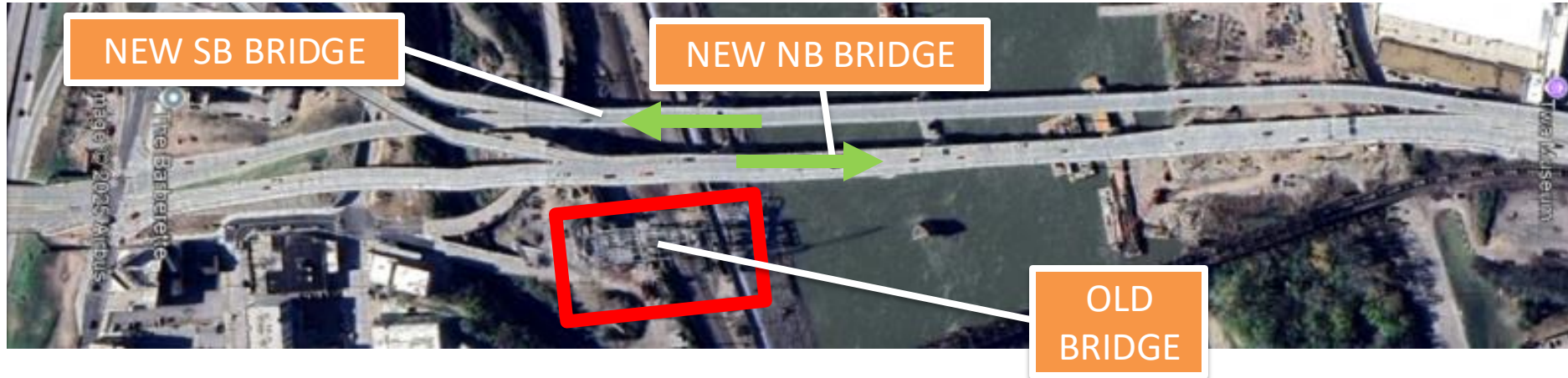

Demolition Sequence

Phase 3



Project Outline

- Project Introduction
- Demo Sequence
- **Unit 1 Demo - TPG**
- Unit 2, 3, & 4 Deck Demo
- Unit 2 & 3 Demo - Steel Plate Girder
- Unit 4 Demo - Tied Arch
- Current Status

Existing Bridge – Unit 1 (TPG)

- SB Demolished 1st
- Straight Through-Plate Girder

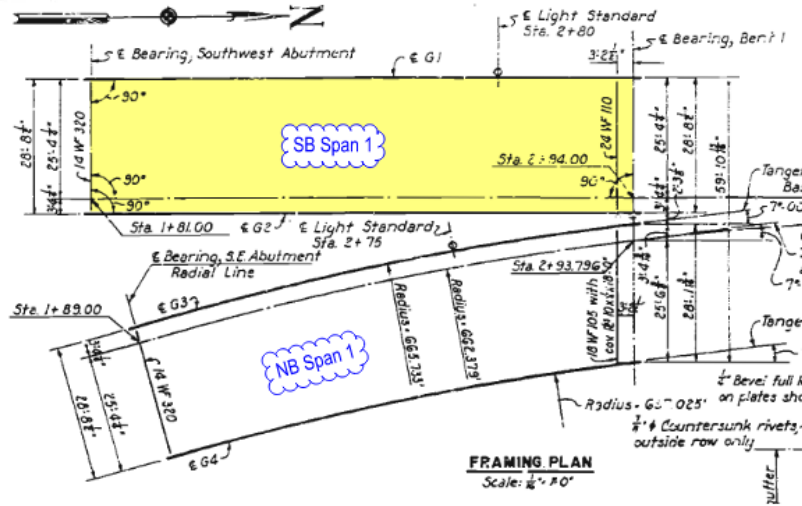

Existing Bridge – Unit 1 (TPG)

- NB Demolished at later phase
- Curved Through-Plate Girder

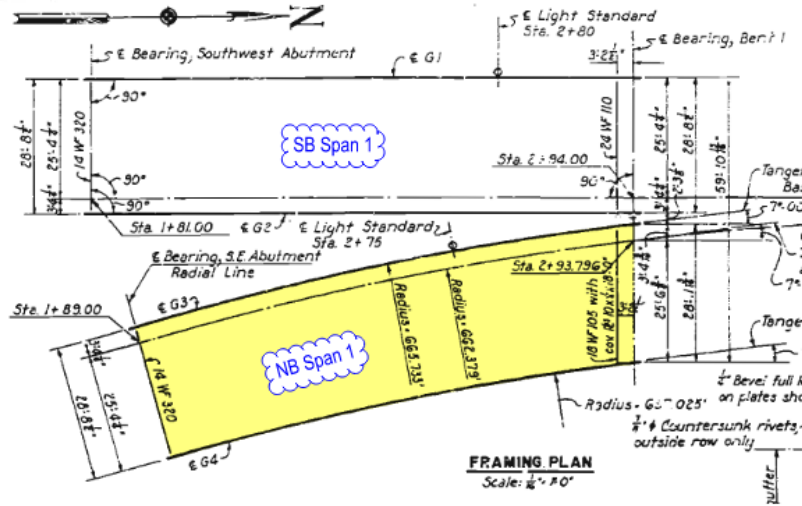

Existing Bridge – Unit 1 (TPG)

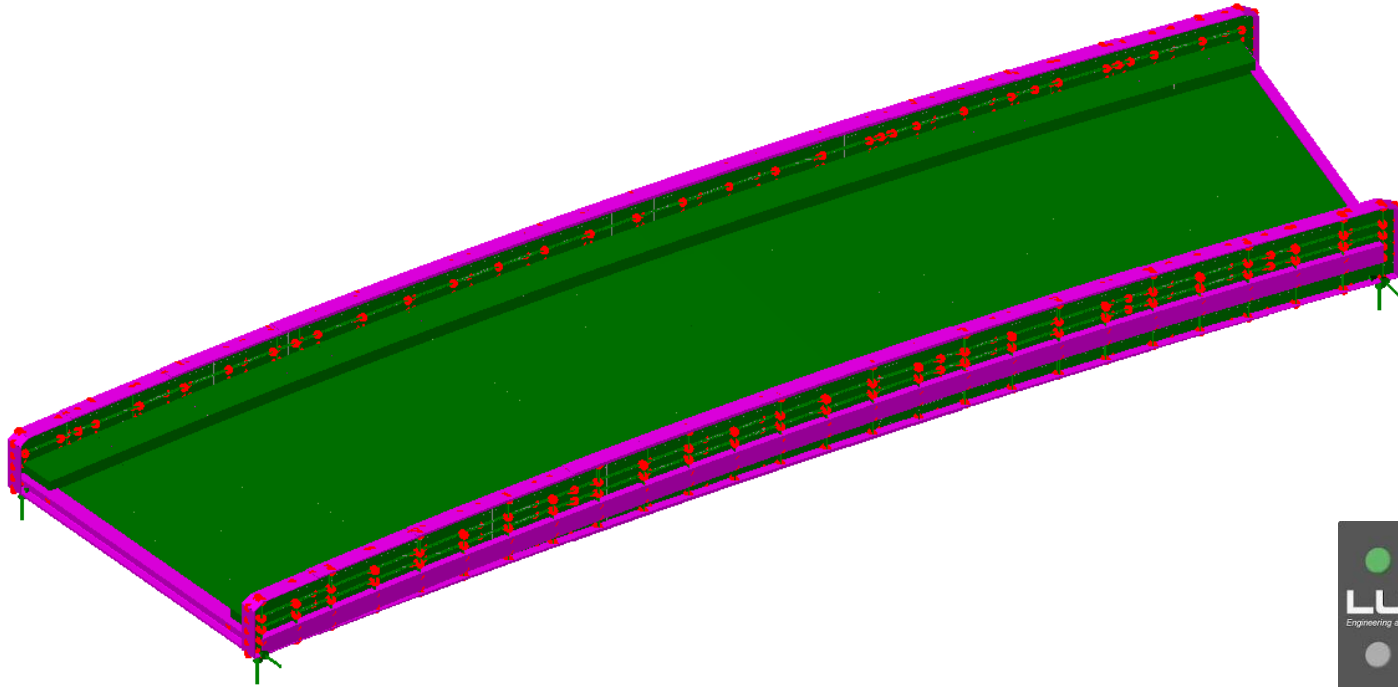

Existing Bridge – Unit 1 (TPG)

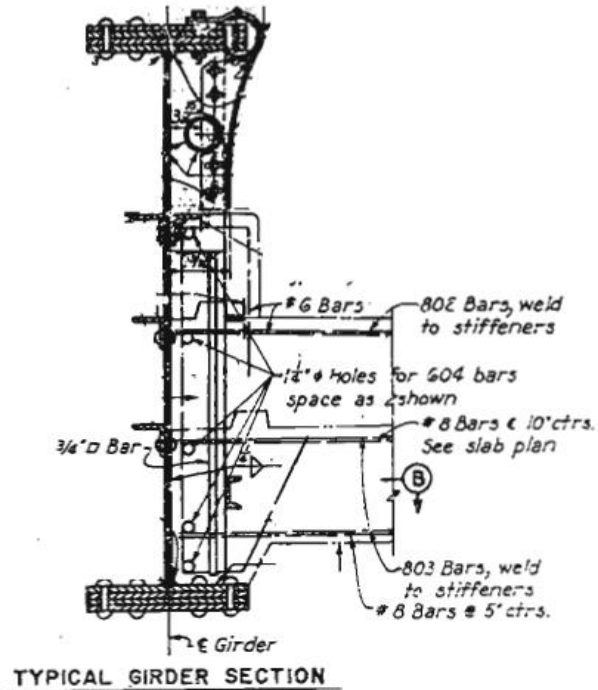

- Flexural Connectivity to between concrete deck and girder

Existing Bridge – Unit 1 (TPG)

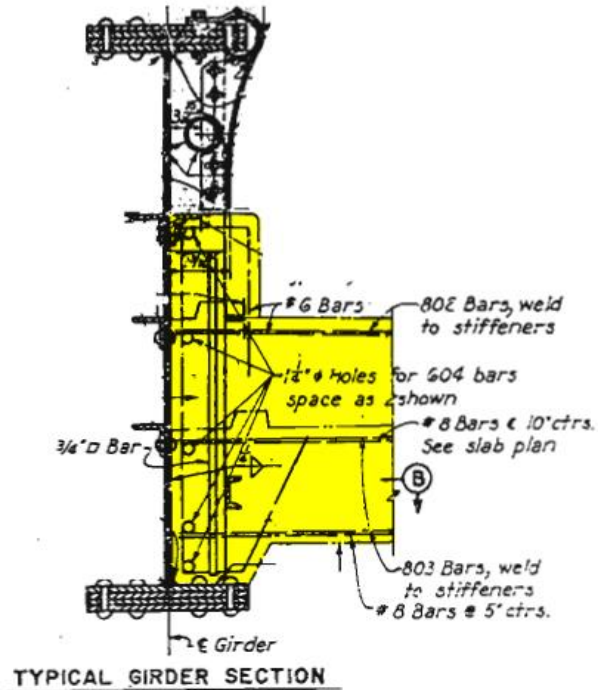

- Flexural Connectivity to between concrete deck and girder
- Concrete deck at interface with Girder

Existing Bridge – Unit 1 (TPG)

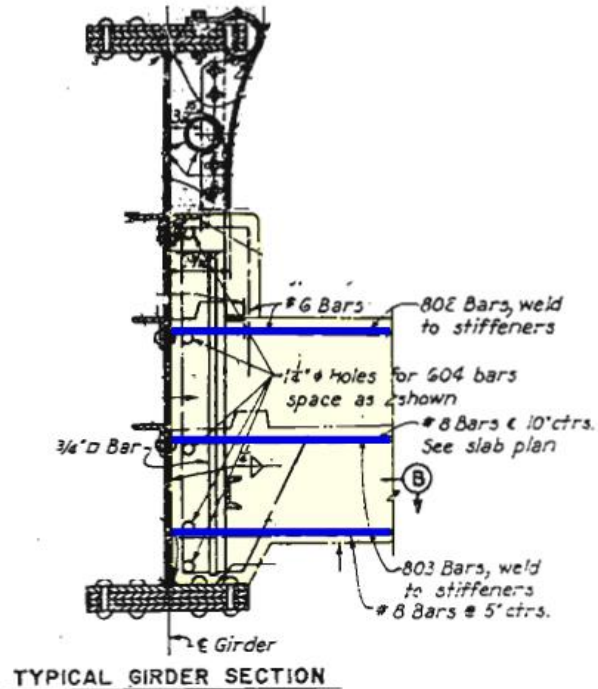

- Flexural Connectivity to between concrete deck and girder
- Welded reinforcing

Existing Bridge – Unit 1 (TPG)

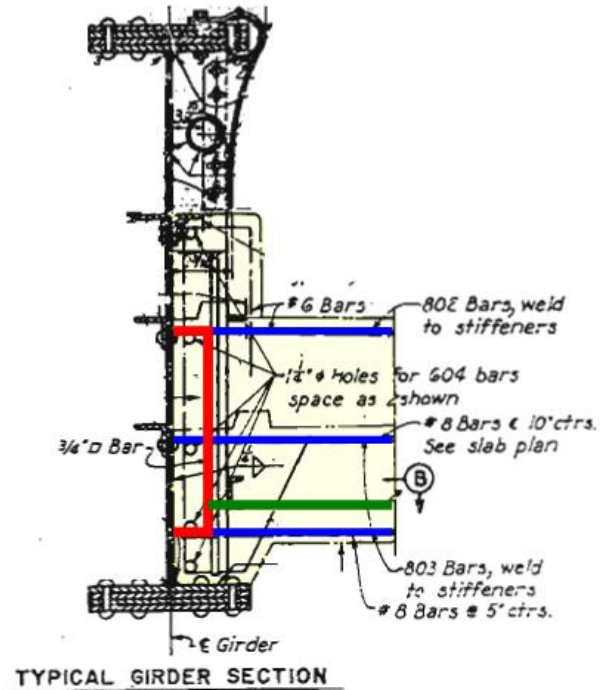

- Flexural Connectivity to between concrete deck and girder
- Represented by frame connection at each vertical stiffener

Existing Bridge – Unit 1 (TPG)

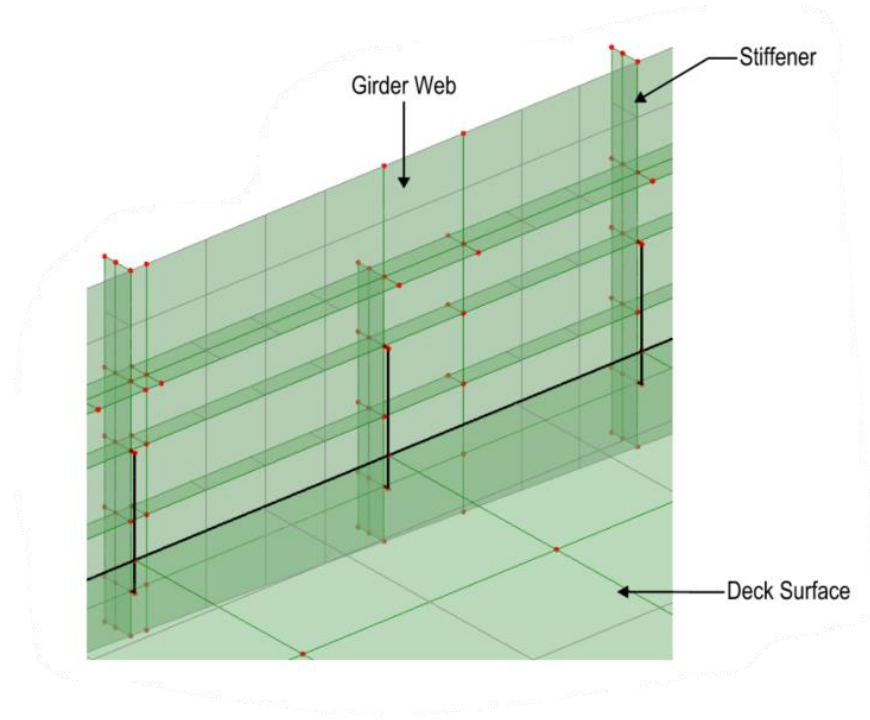

Existing Bridge – Unit 1 (TPG)

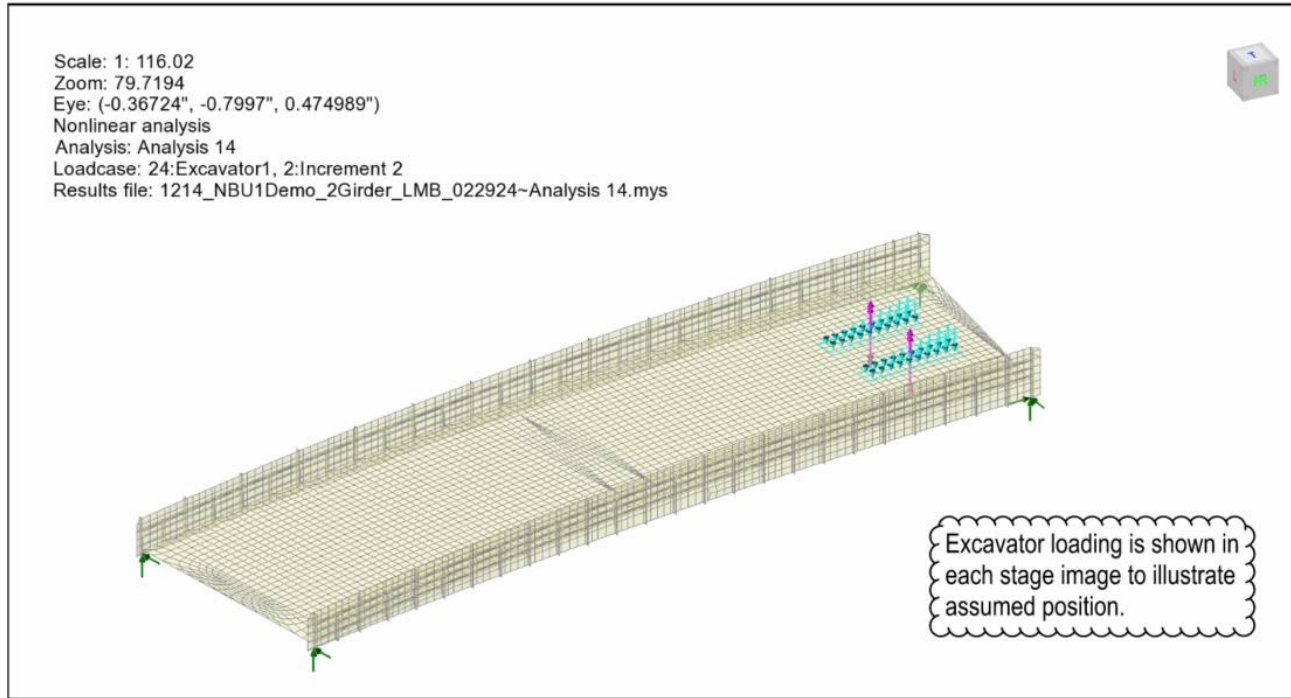

Existing Bridge – Unit 1 (TPG)

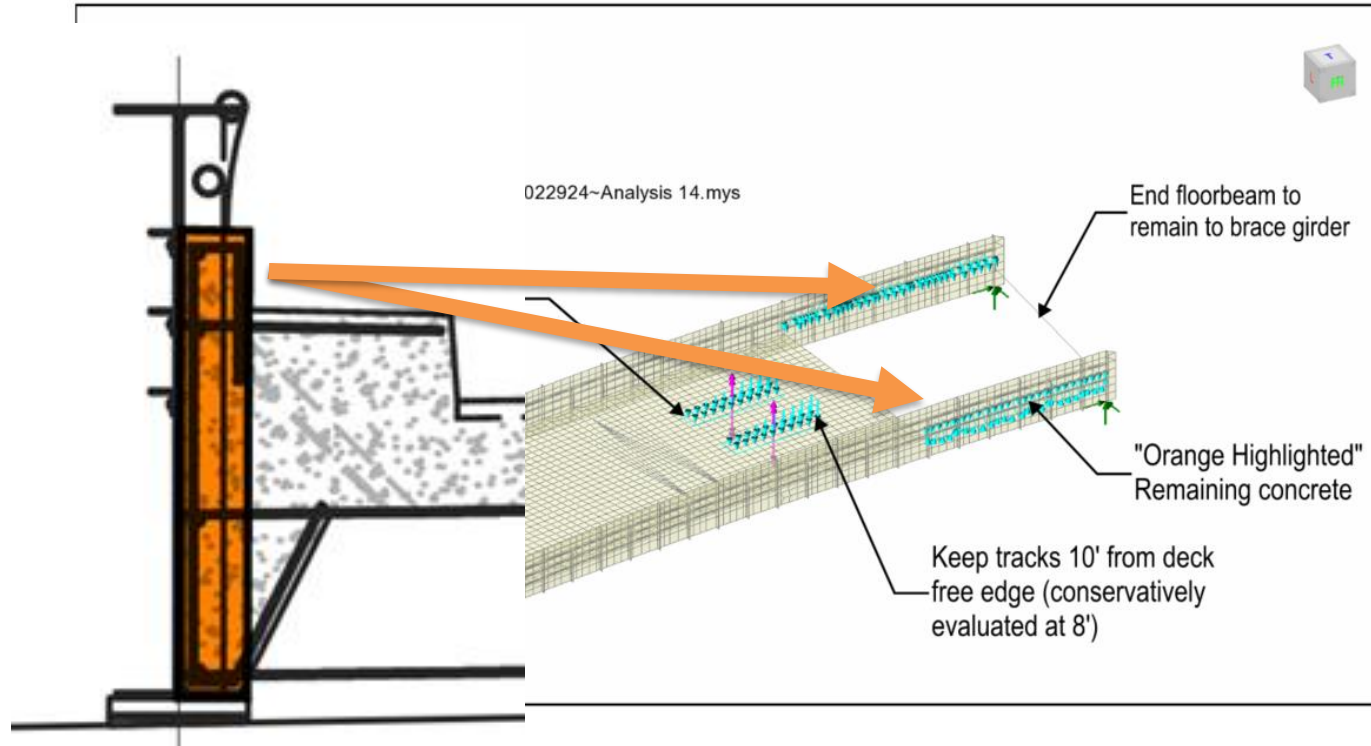

Existing Bridge – Unit 1 (TPG)



Existing Bridge – Unit 1 (TPG)

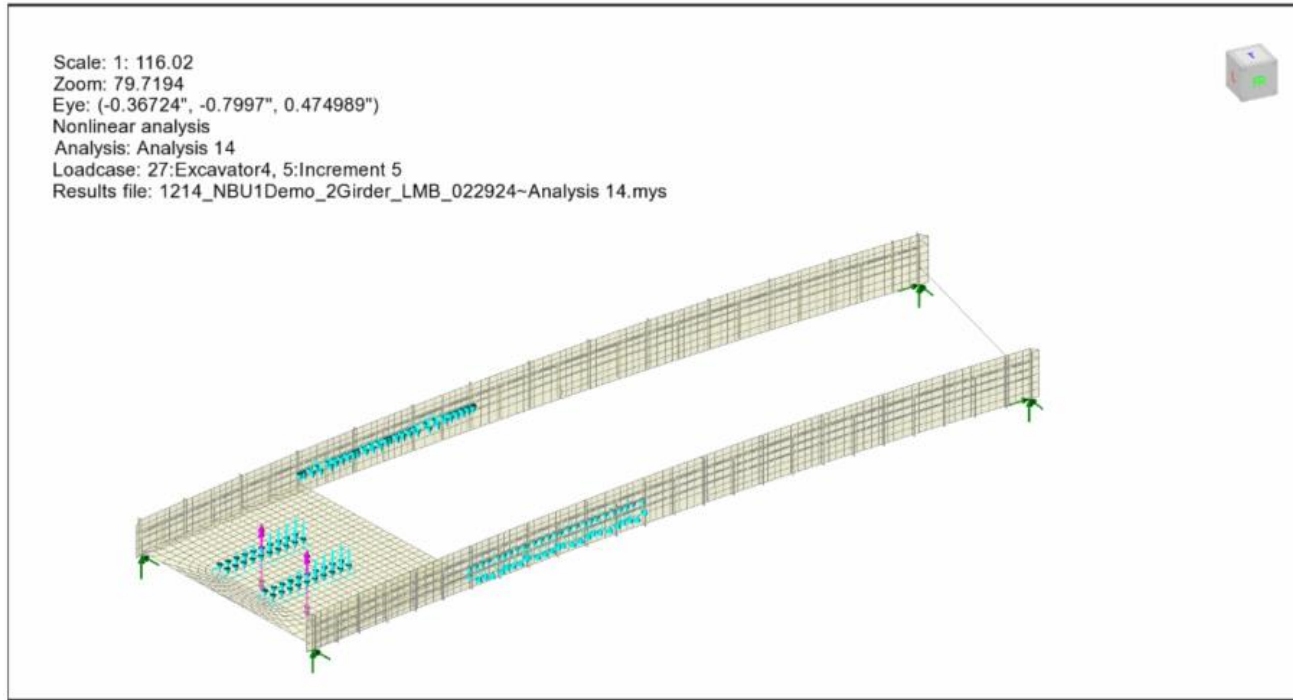

Existing Bridge – Unit 1 (TPG)

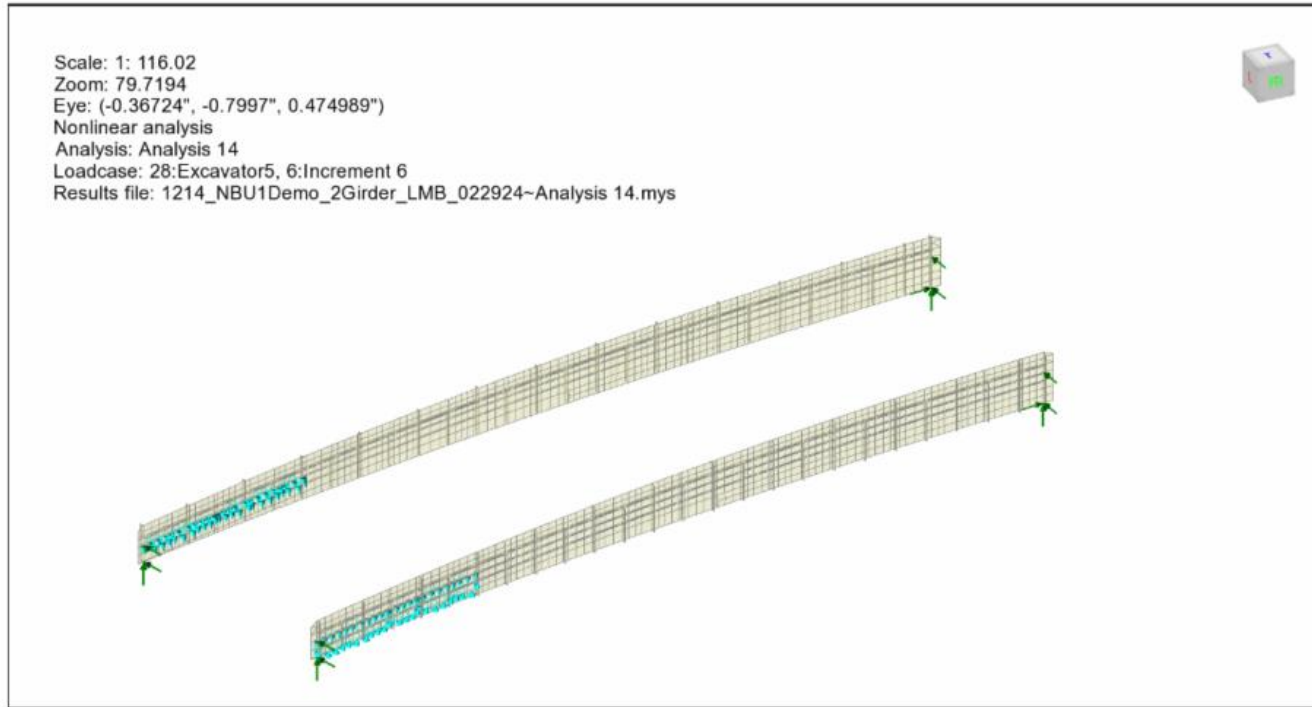

Existing Bridge – Unit 1 (TPG)

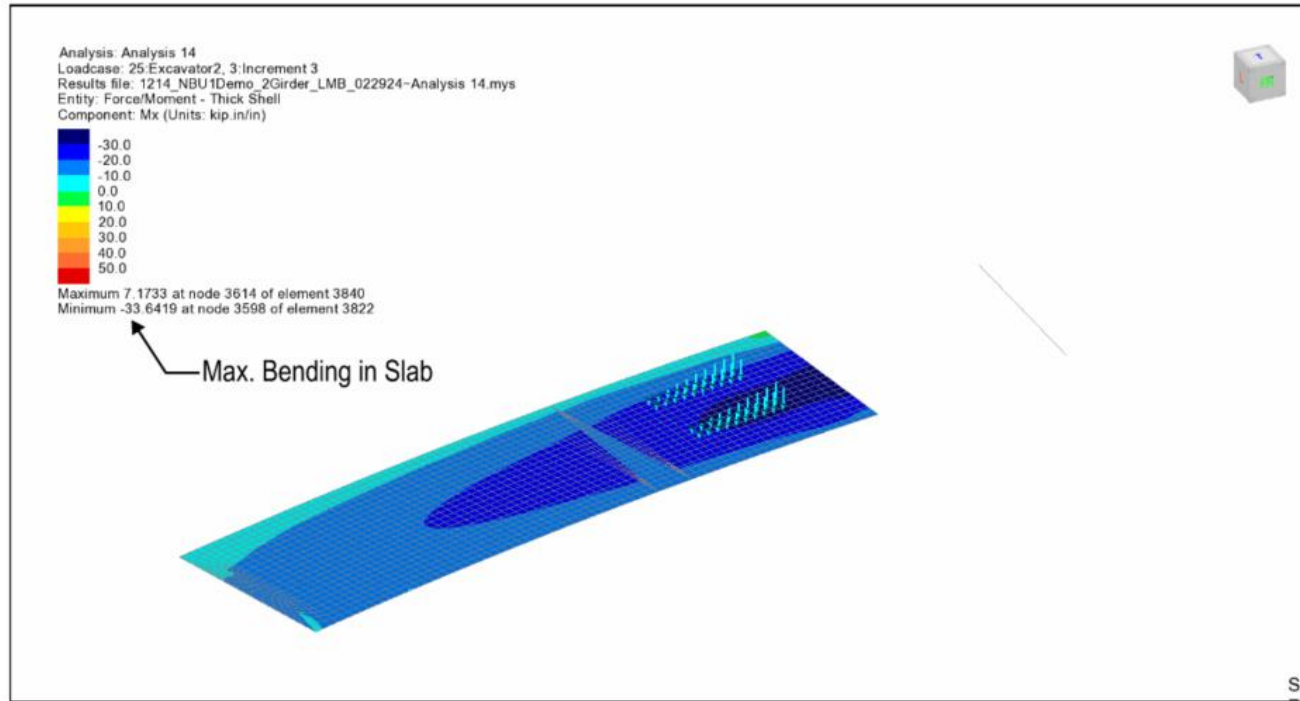

Existing Bridge – Unit 1 (TPG)

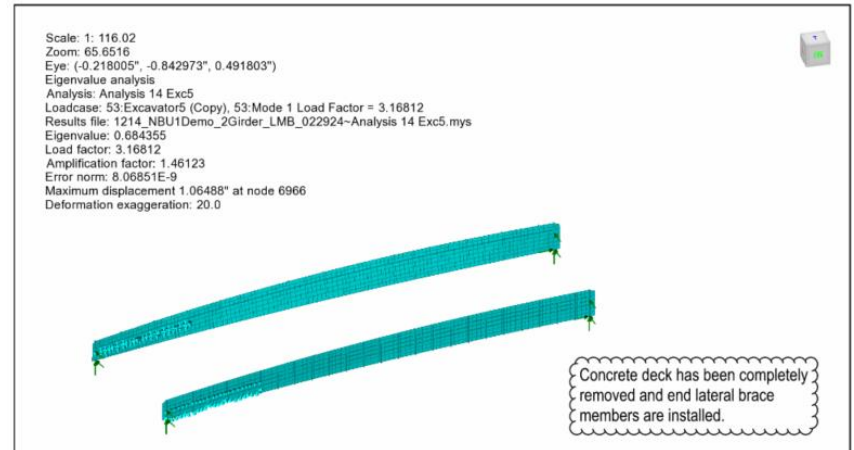
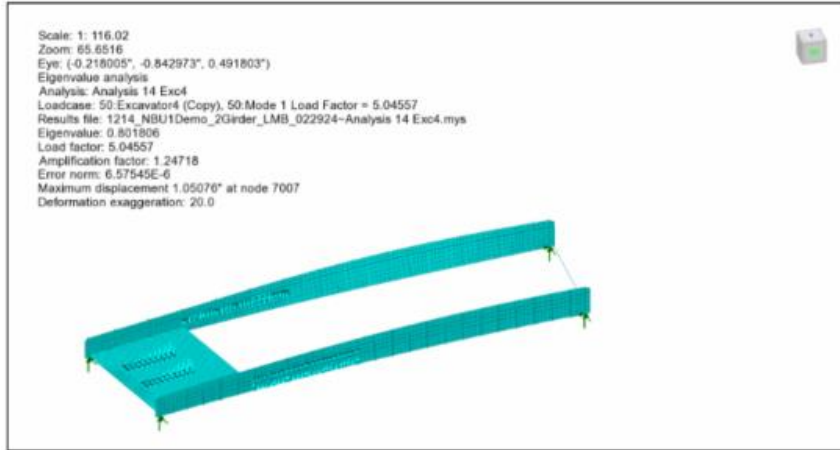

Existing Bridge – Unit 1 (TPG)



Existing Bridge – Unit 1 (TPG)



Existing Bridge – Unit 1 (TPG)



Existing Bridge – Unit 1 (TPG)



Project Outline

- Project Introduction
- Demo Sequence
- Unit 1 Demo - TPG
- **Unit 2, 3, & 4 Deck Demo**
- Unit 2 & 3 Demo - Steel Plate Girder
- Unit 4 Demo - Tied Arch
- Current Status

Unit 2,3, & 4 Deck Demo



- Conventional Deck Demo Methods
 - Hydraulic Hammer

Unit 2,3, & 4 Deck Demo



- Conventional Deck Demo Methods
 - Hydraulic Hammer
 - Saw Cut & Slab Crab

Unit 2,3, & 4 Deck Demo

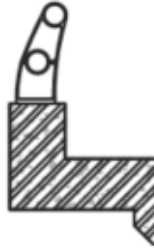

an curb prior to
ations (see Note 3)
rder

Unit 2,3, & 4 Deck Demo

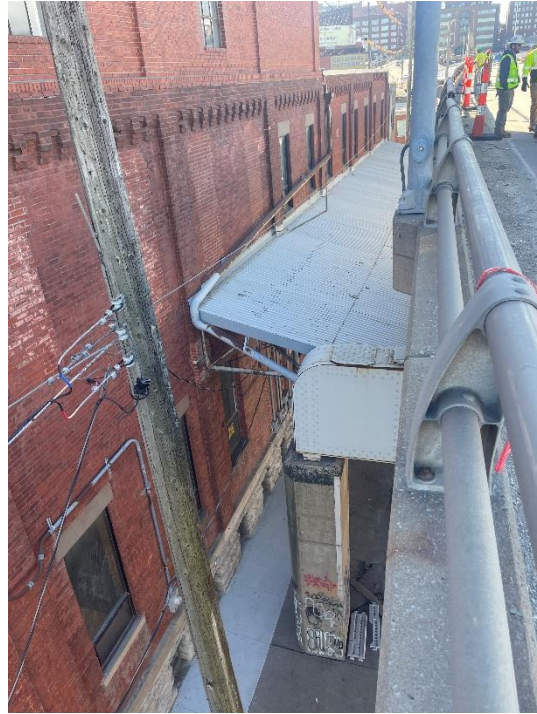

Unit 2,3, & 4 Deck Demo



Unit 2,3, & 4 Deck Demo



Unit 2,3, & 4 Deck Demo



Project Outline

- Project Introduction
- Demo Sequence
- Unit 1 Demo - TPG
- Unit 2, 3, & 4 Deck Demo
- **Unit 2 & 3 Demo - Steel Plate Girder**
- Unit 4 Demo - Tied Arch
- Current Status

Unit 2 & 3 Girder Removal



- Conventional Girder Removal Methods
 - Single Girder Picks
 - Paired Girder Picks
 - Inclined Rigging

Unit 2 & 3 Girder Removal

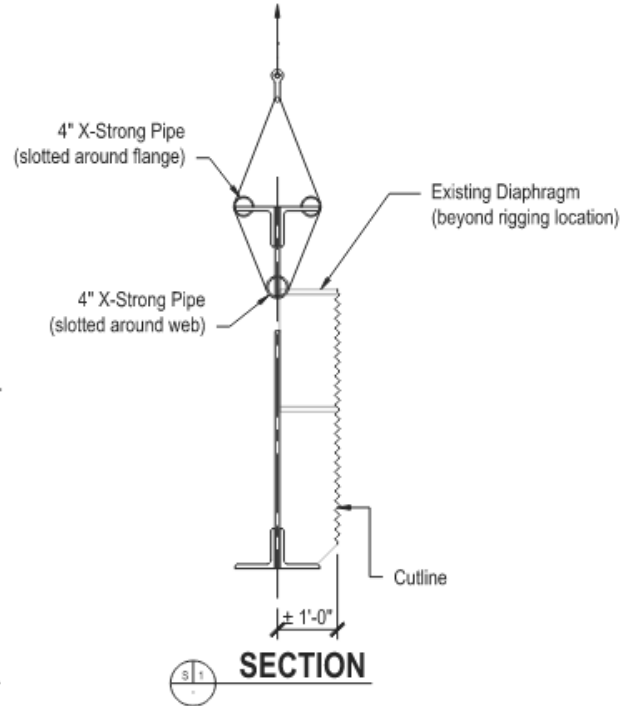
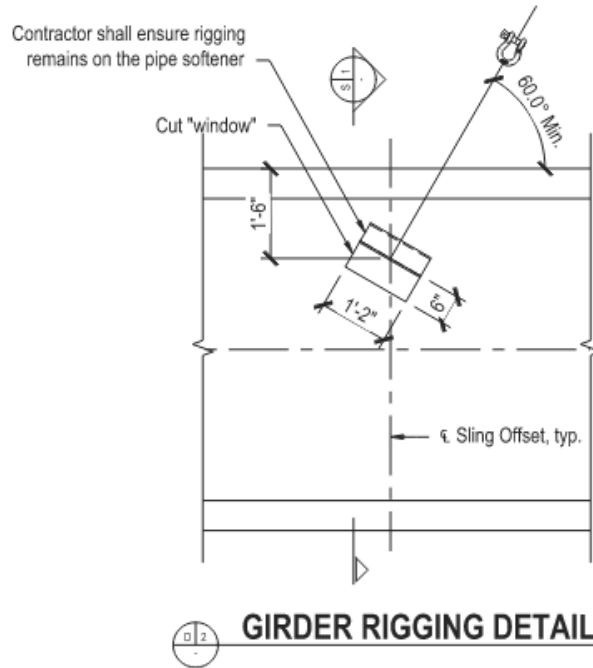

Unit 2 & 3 Girder Removal



Unit 2 & 3 Girder Removal

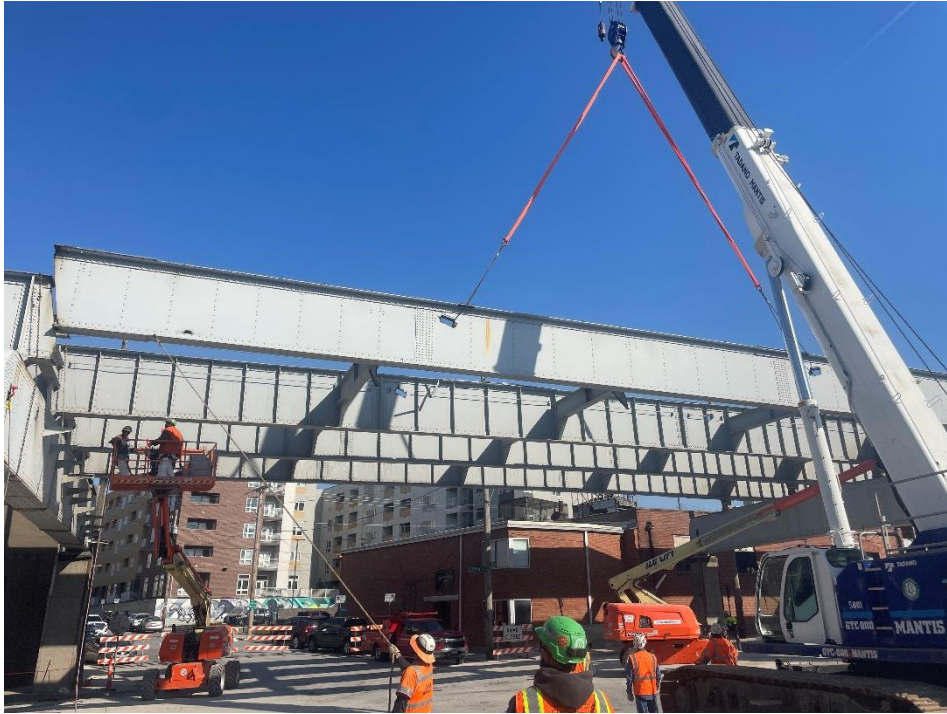

Unit 2 & 3 Girder Removal



Unit 2 & 3 Girder Removal



Unit 2 & 3 Girder Removal

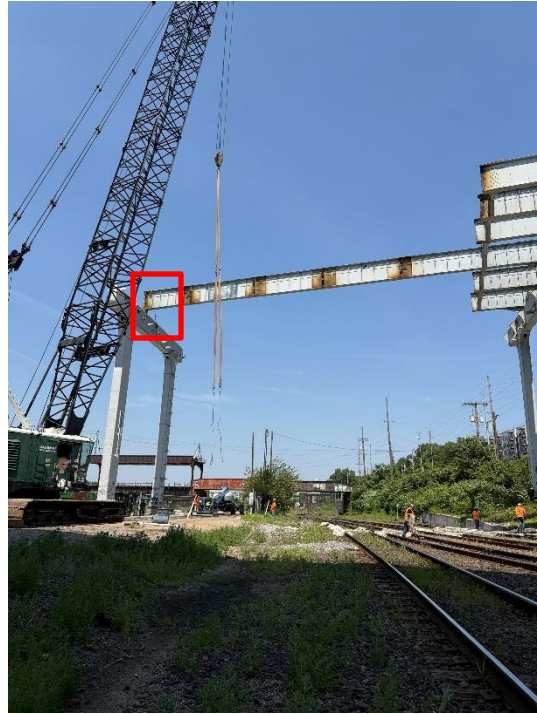

Unit 2 & 3 Girder Removal



Project Outline

- Project Introduction
- Demo Sequence
- Unit 1 Demo - TPG
- Unit 2, 3, & 4 Deck Demo
- Unit 2 & 3 Demo - Steel Plate Girder
- **Unit 4 Demo - Tied Arch**
- Current Status

Main Span Demo

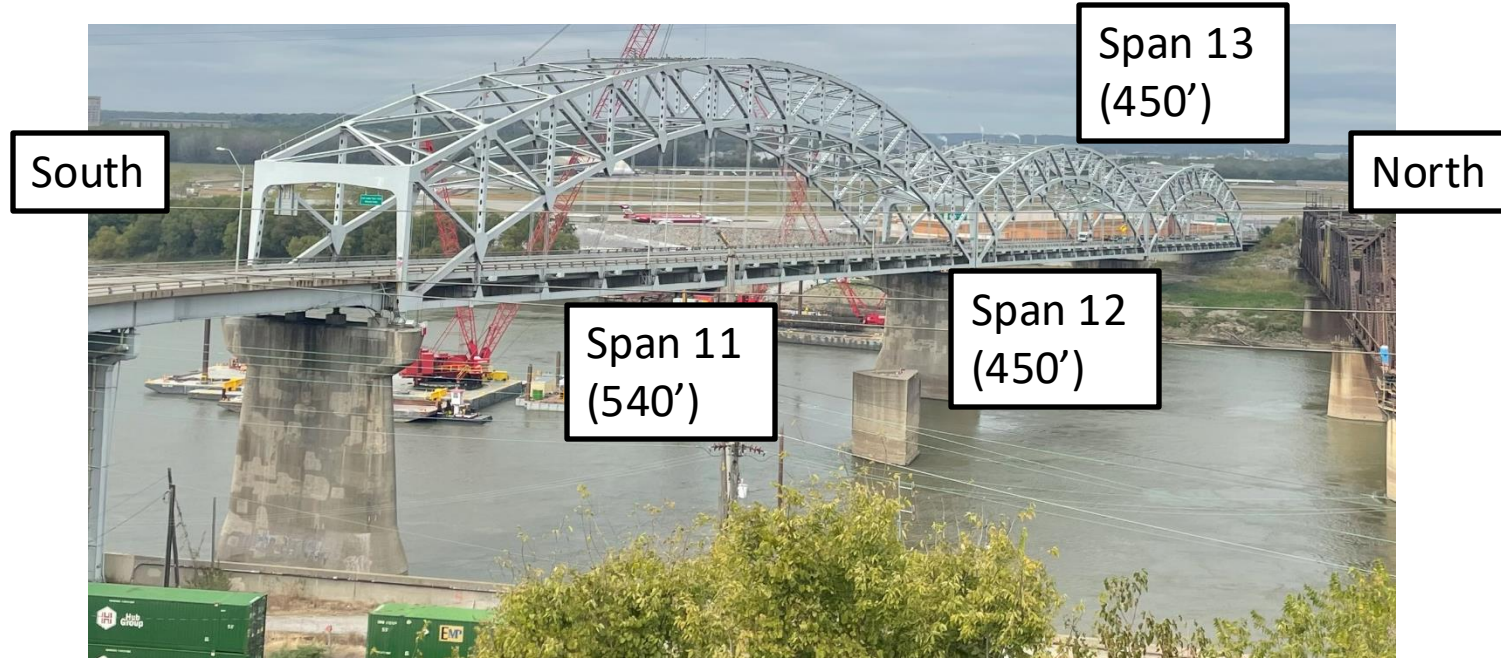

Main Span Demo



Span 13: Pre-Cut Layout

450' Span

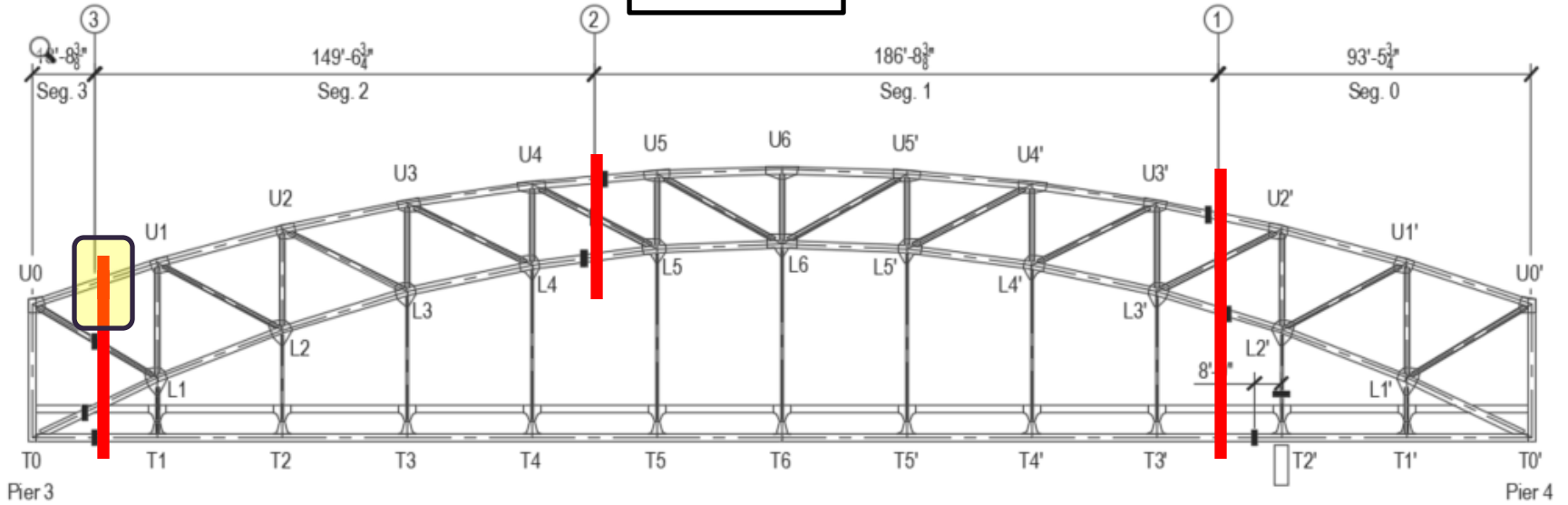

Pre-Cut Section: Main Arch

Original Section

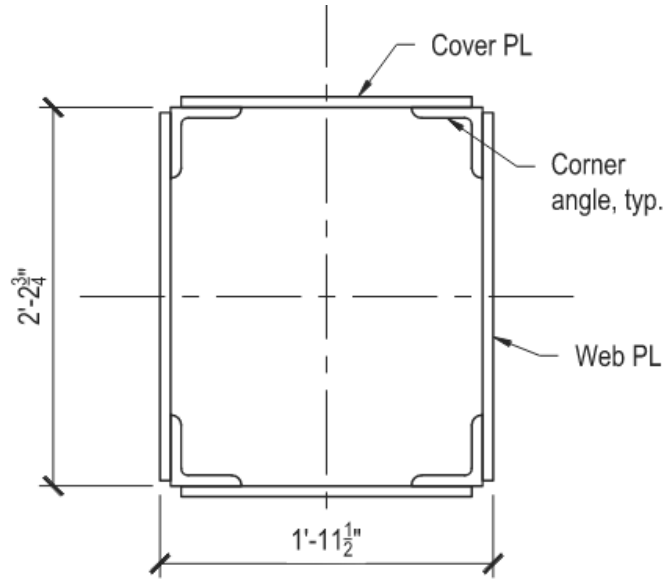

Pre-Cut Section

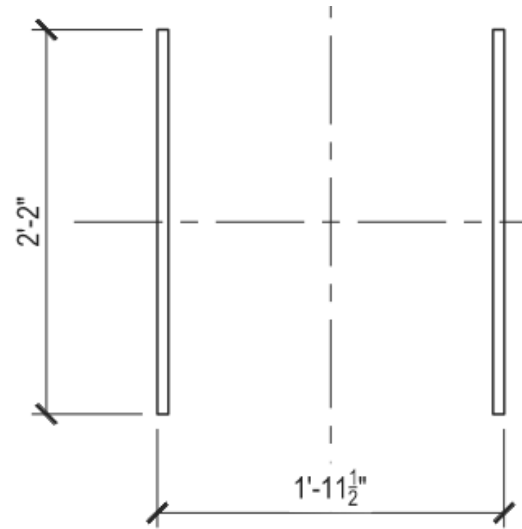

Pre-Cut Section: Main Arch



Linear Shape Charge

Explosives Contractor: Veit
LSC Supplier: AES

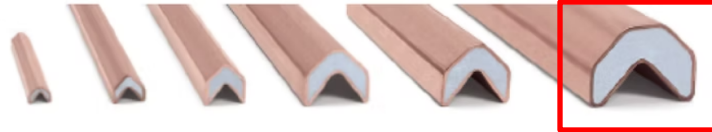

COPPER LINEAR

Core Load Grains/Foot*	
125	
250	
400	
600	
900	
1,200	
2,000	
3,200	
4,000	

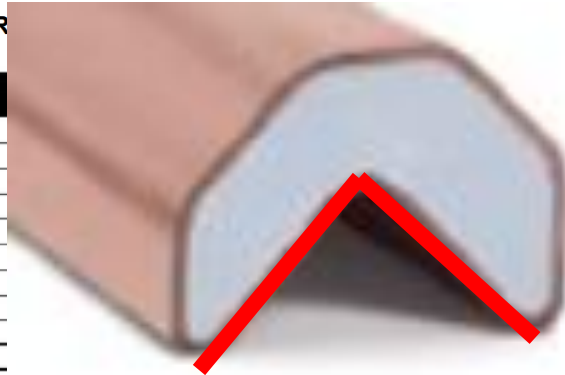

at Optimum ff (In.)
0
0
0
0
0
5
10
10
0
10

COE Levee Wall

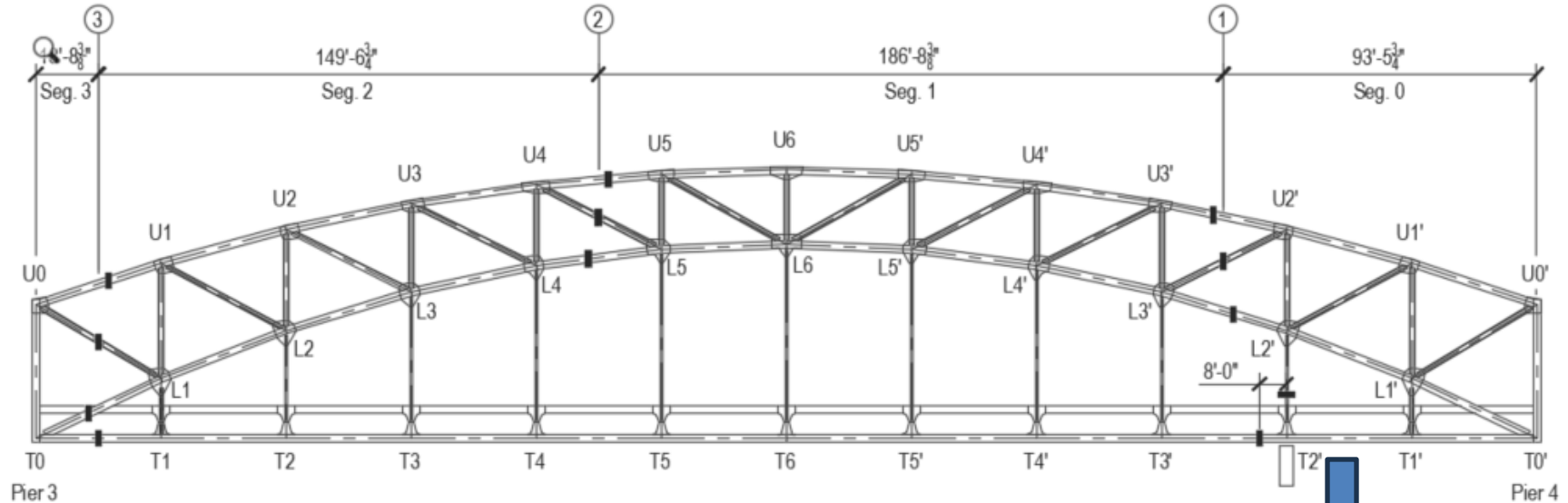

Core of Engineers Levee Wall



COE Levee Wall



Temporary Works

- Temporary Bent
- Temporary Post
- Uplift Restraint
- Arch Member Eval

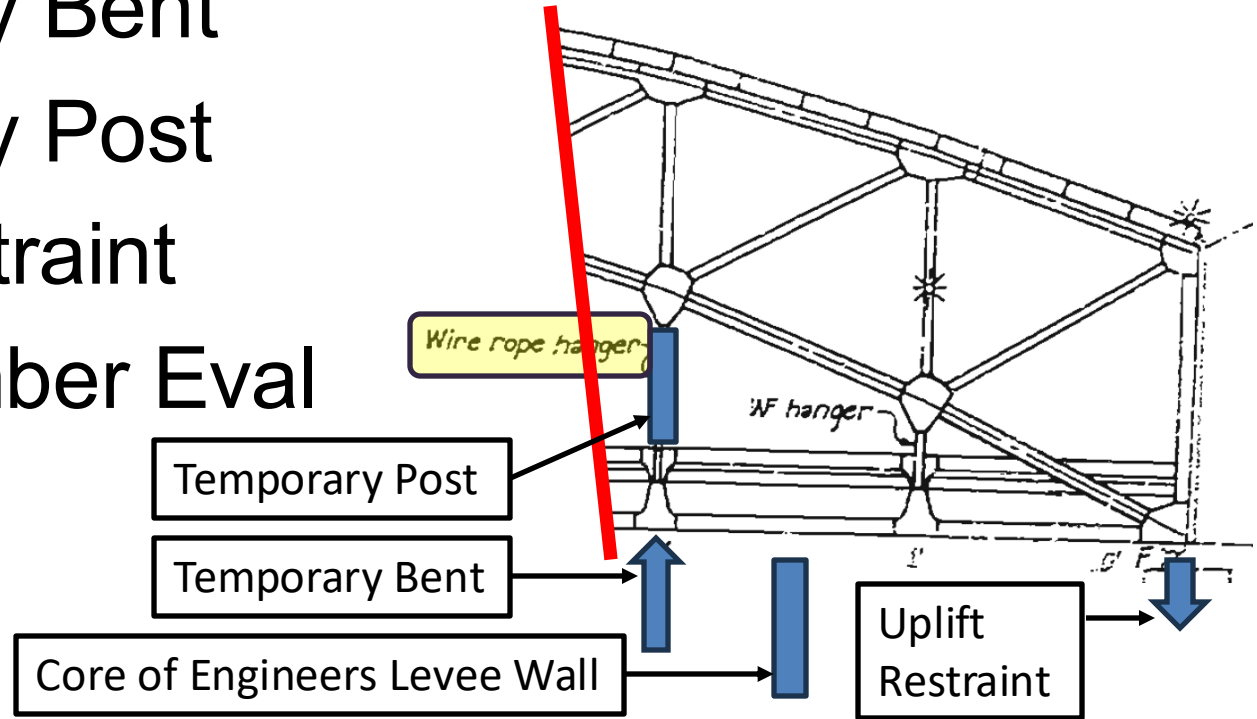

Dynamic Analysis Model

- Instantaneous Loss of Mass
- Remaining Structure Dynamic Response
- Lusas Transient Dynamic Analysis

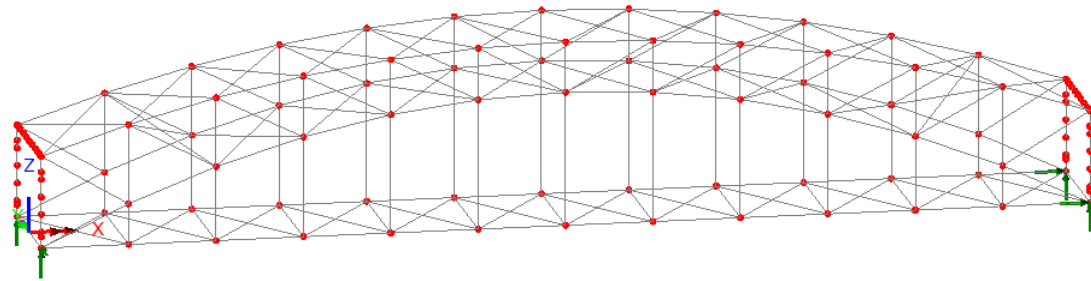

Dynamic Analysis Model

- Natural Frequency (1st & 2nd Mode)
- Rayleigh Damping Constants (Mass & Stiffness)

	Value
Young's modulus	29.0E3
Poisson's ratio	0.3
Mass density	0.7342E-6
Coefficient of thermal expansion	6.5E-6

Dynamic Analysis Model

- Concrete Column w/
Soil Interaction
 - Contact Spring
Stiffness = 2200 kli
- Uplift Restraint
System
 - Lift-Off Spring
Stiffness = 115 kli

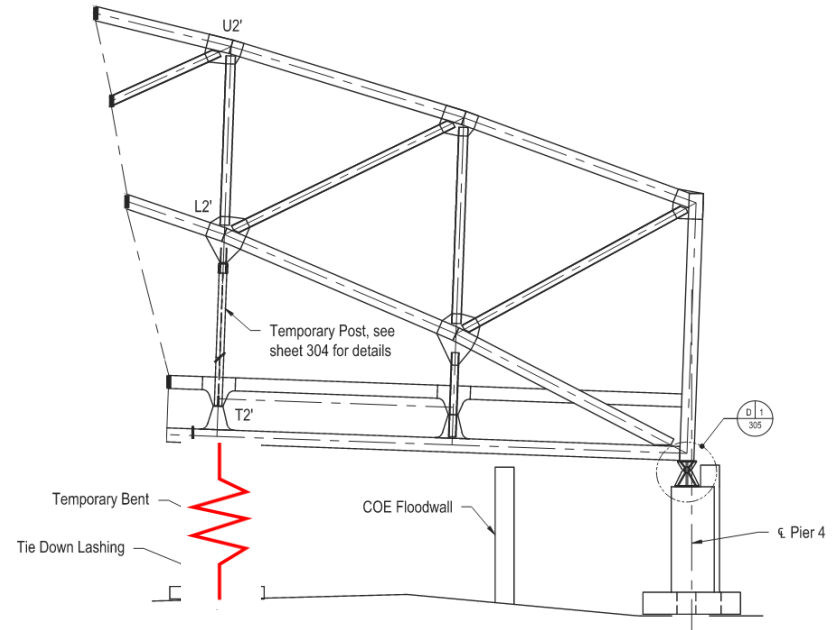

Temporary Bent

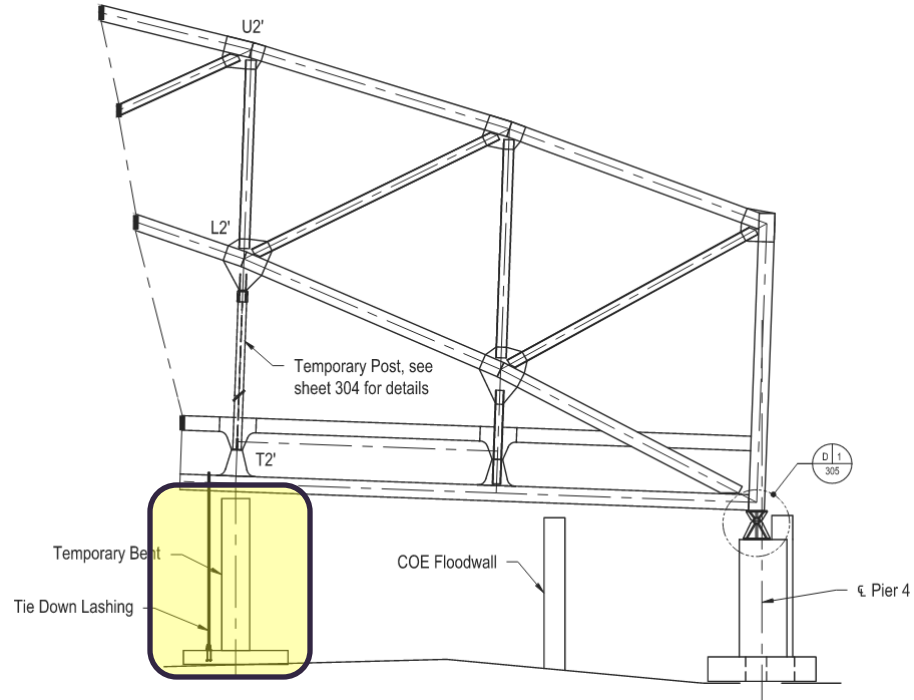

Temporary Bent Design

- Column Design
- Footing Design
- Local Truss Evaluation
- Uplift Restraint

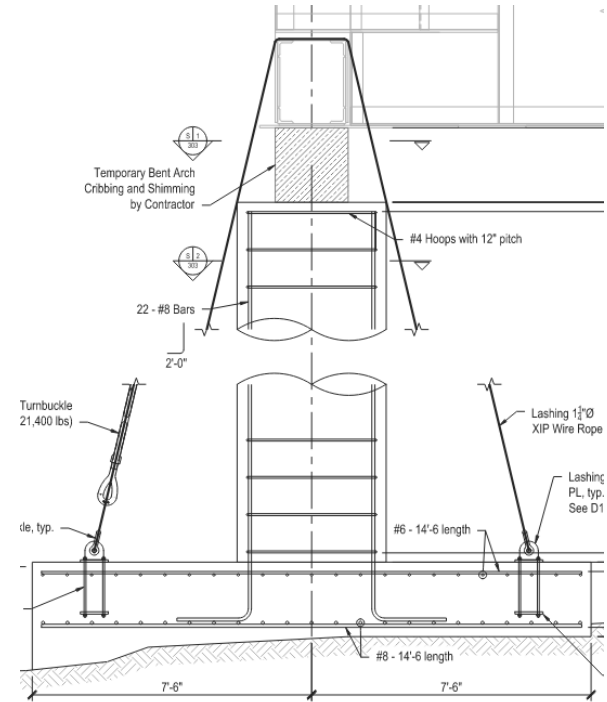

Temporary Bent Demand

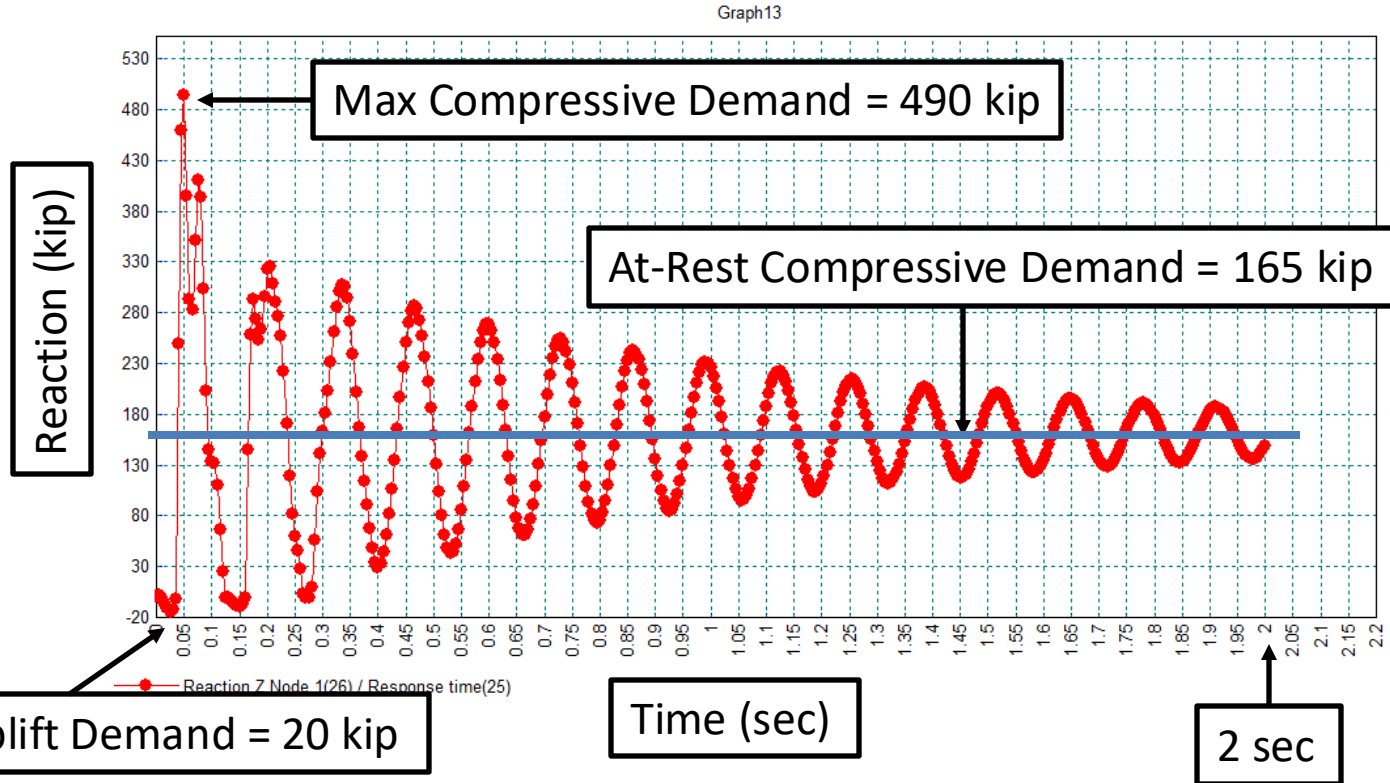

Temporary Bent Photos



Temporary Post

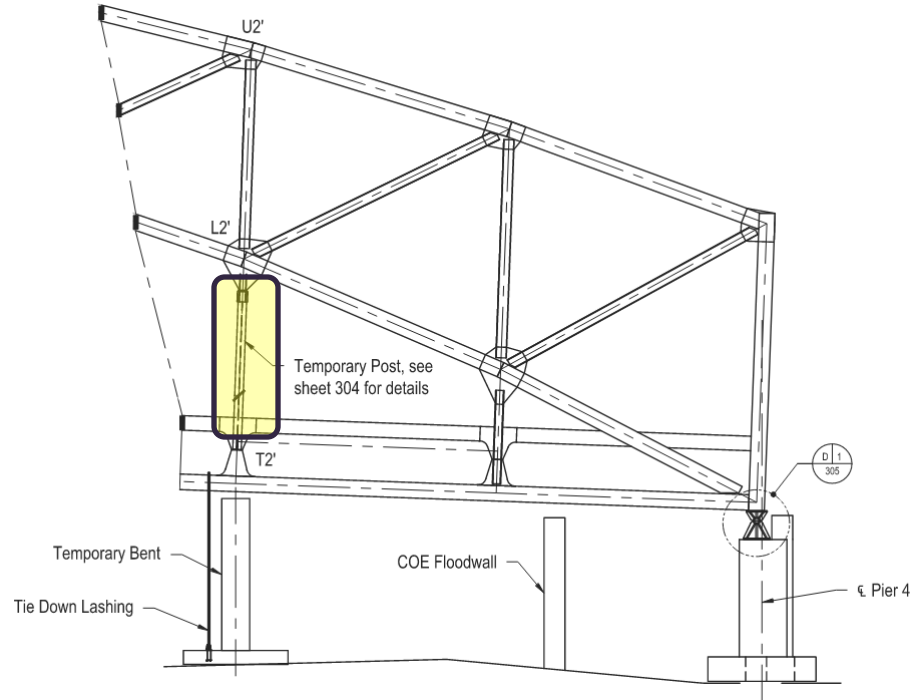

Temporary Post

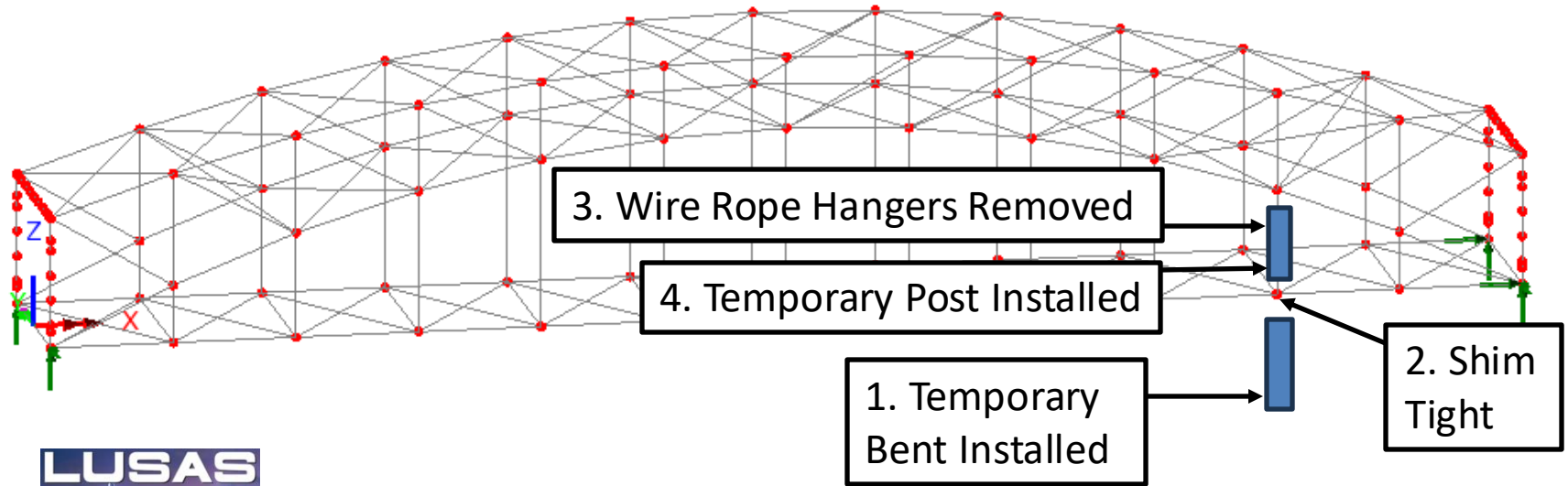

Temporary Post

- Column Design
- Upper Connection
- Lower Connection
- Local Truss Evaluation



Temporary Post Demand

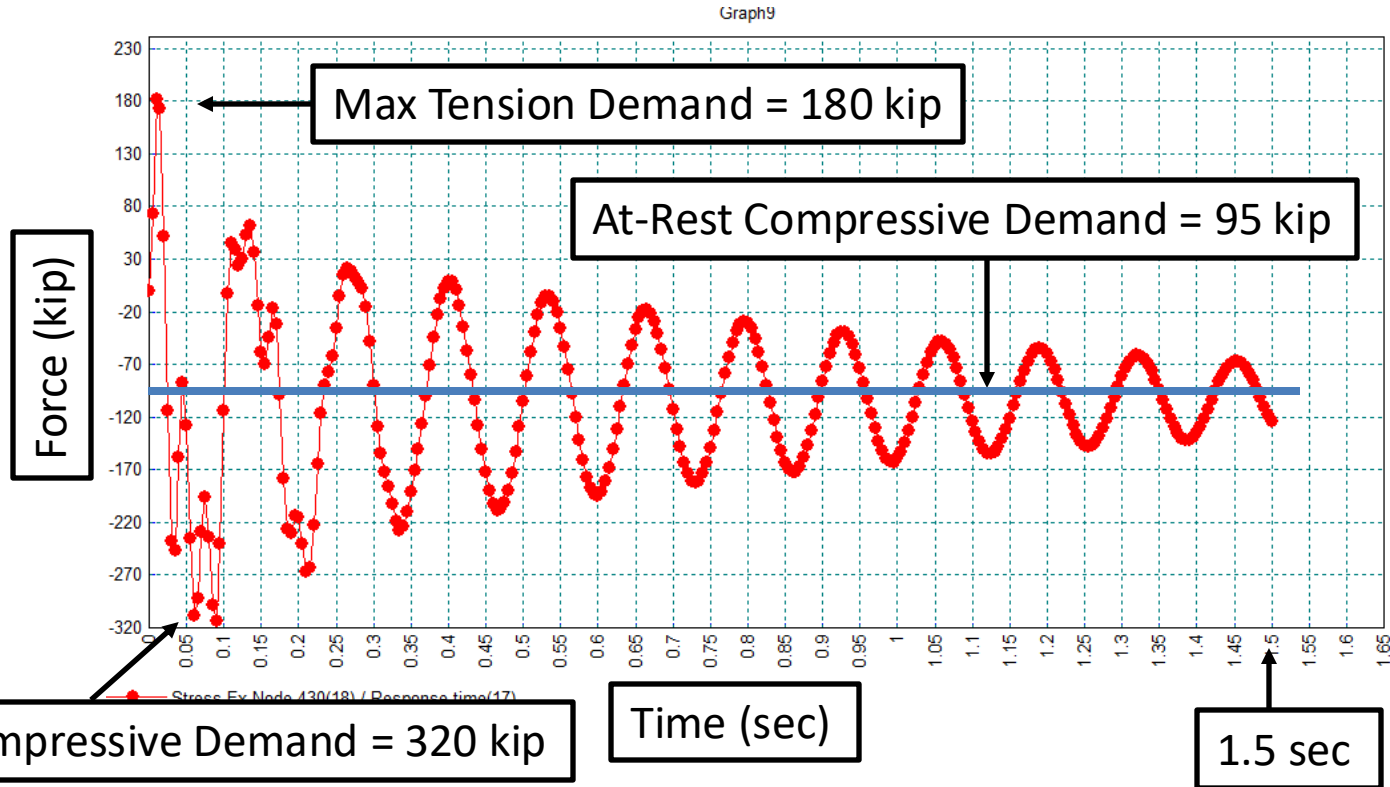

Temporary Post Length



Temporary Post Length

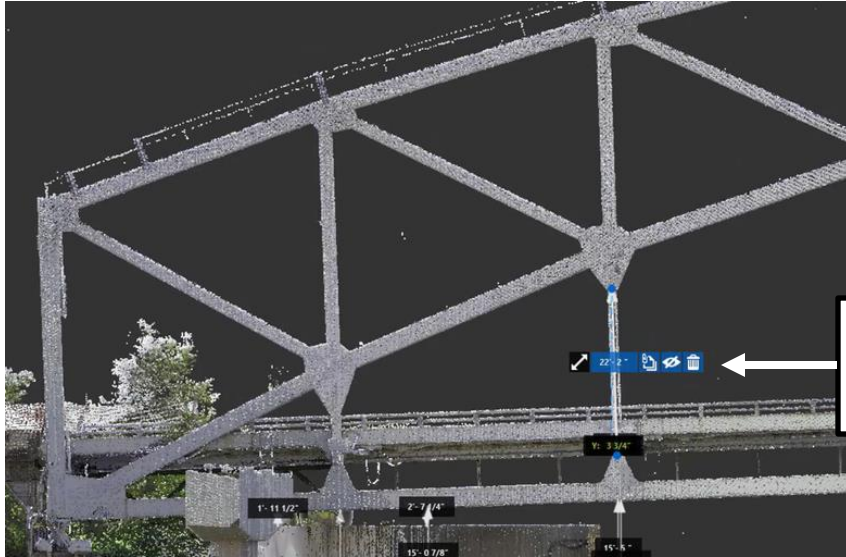

As-Measured Length = 22'-2"

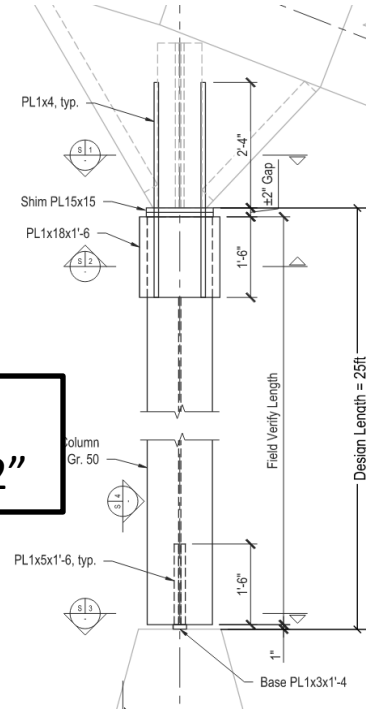

Temporary Post Connections

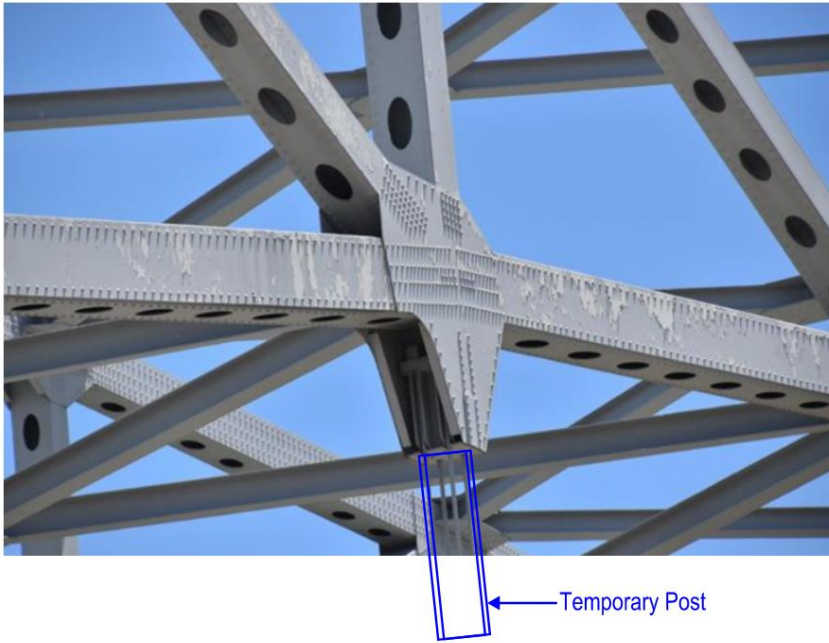

Temporary Post Connections



Pier 4 Bearing Restraint

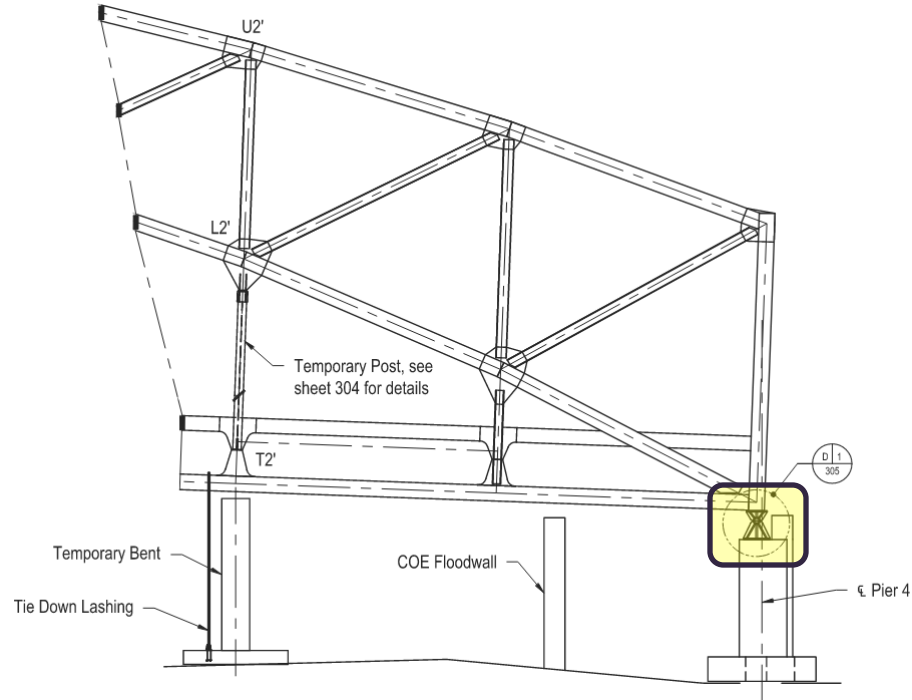

Pier 4 Bearing Restraint

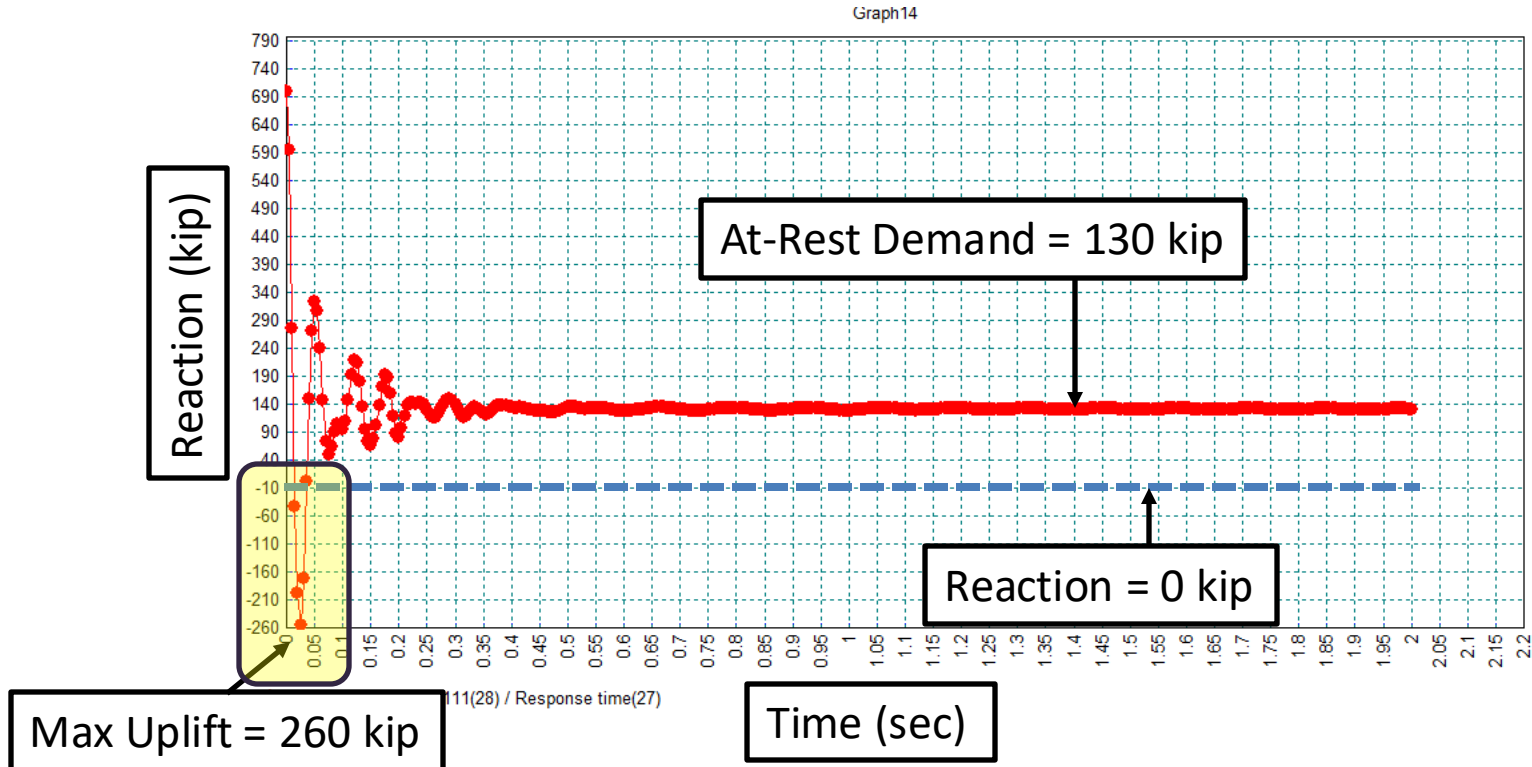

Pier 4 Bearing Restraint

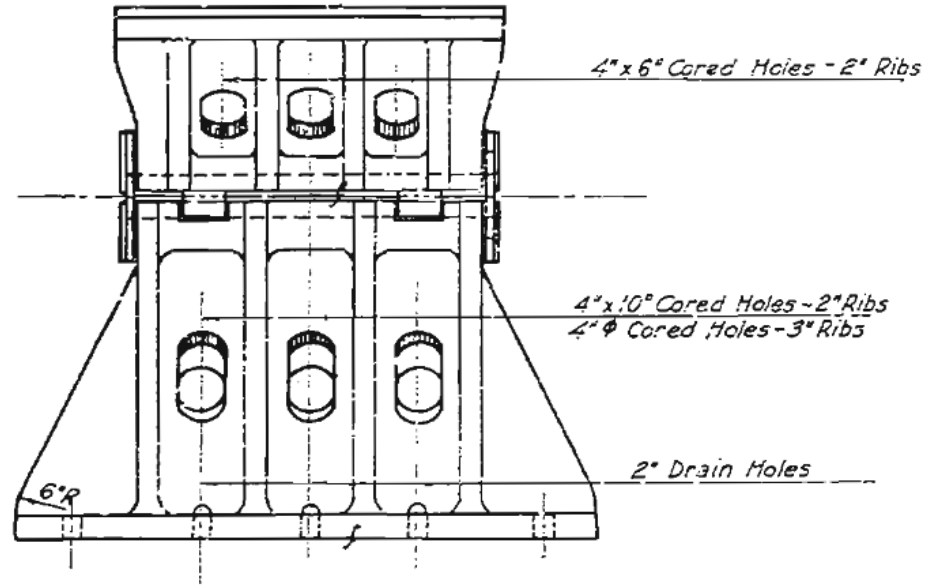
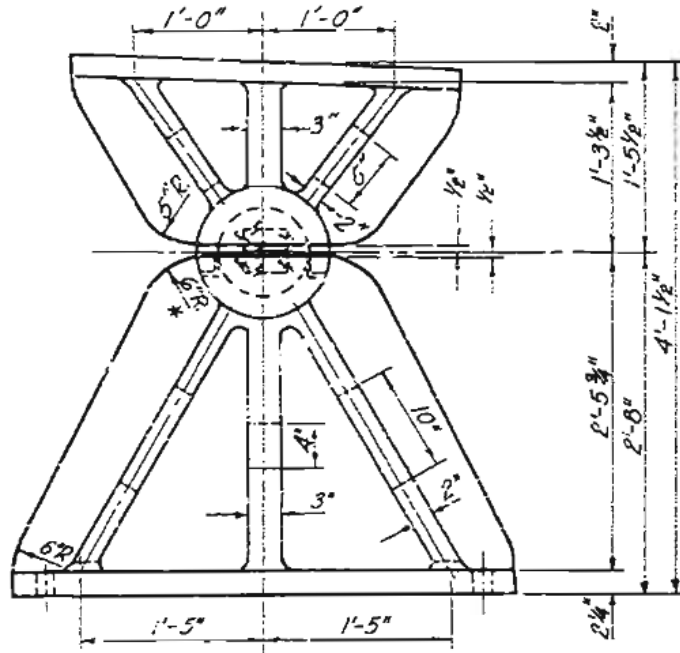

Pier 4 Bearing Restraint



Pier 4 Bearing Restraint



Truss Evaluation

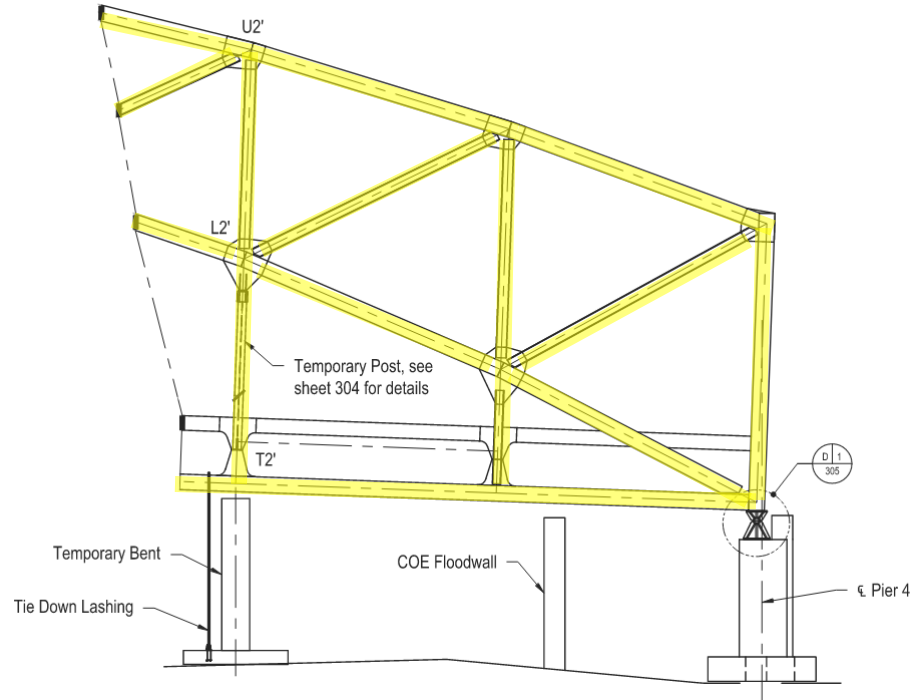

Span 13 Blast Video



Span 13 Post Blast



Piecewise Truss Removal



Span 11: Pre-Cut Layout

540' Span

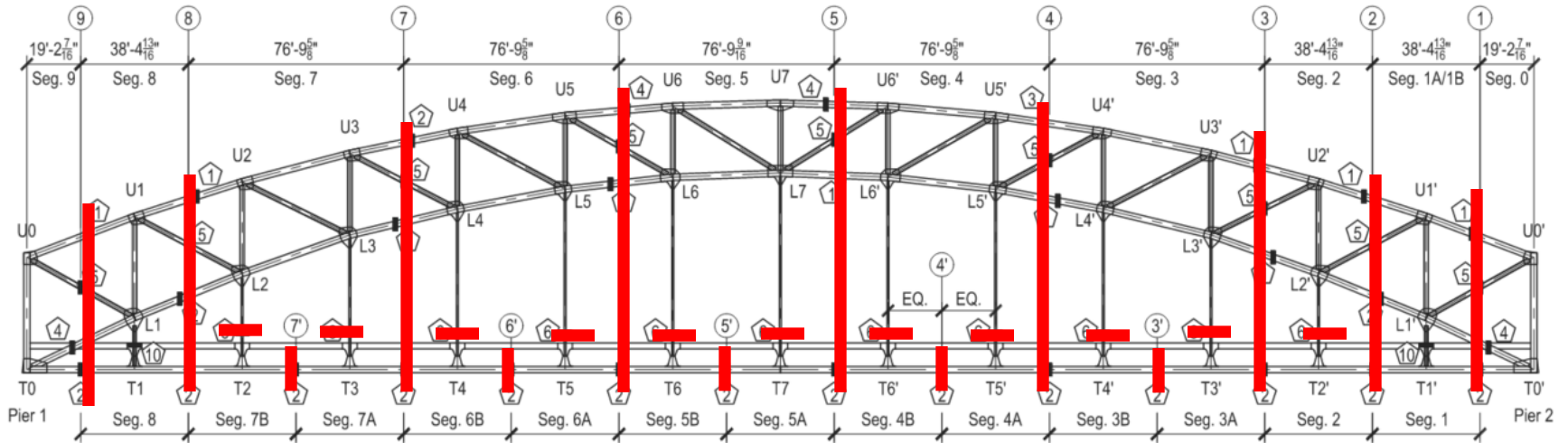

Span 11 Blast Video



Span 11 Post Blast



Project Outline

- Project Introduction
- Demo Sequence
- Unit 1 Demo - TPG
- Unit 2, 3, & 4 Deck Demo
- Unit 2 & 3 Demo - Steel Plate Girder
- Unit 4 Demo - Tied Arch
- **Current Status**

Current Status



Questions?

