

Sequenced Removal of the Non-Redundant I-30 Bridge

Steve Eads, Genesis Structures

IBC 24-80



Presentation Outline

- Project Introduction
- Pre-Demolition Activities
- Deck & Misc Steel Removal
- Girder Removal
- Current Status

Presentation Outline

- **Project Introduction**
- Pre-Demolition Activities
- Deck & Misc Steel Removal
- Girder Removal
- Current Status

Project Location

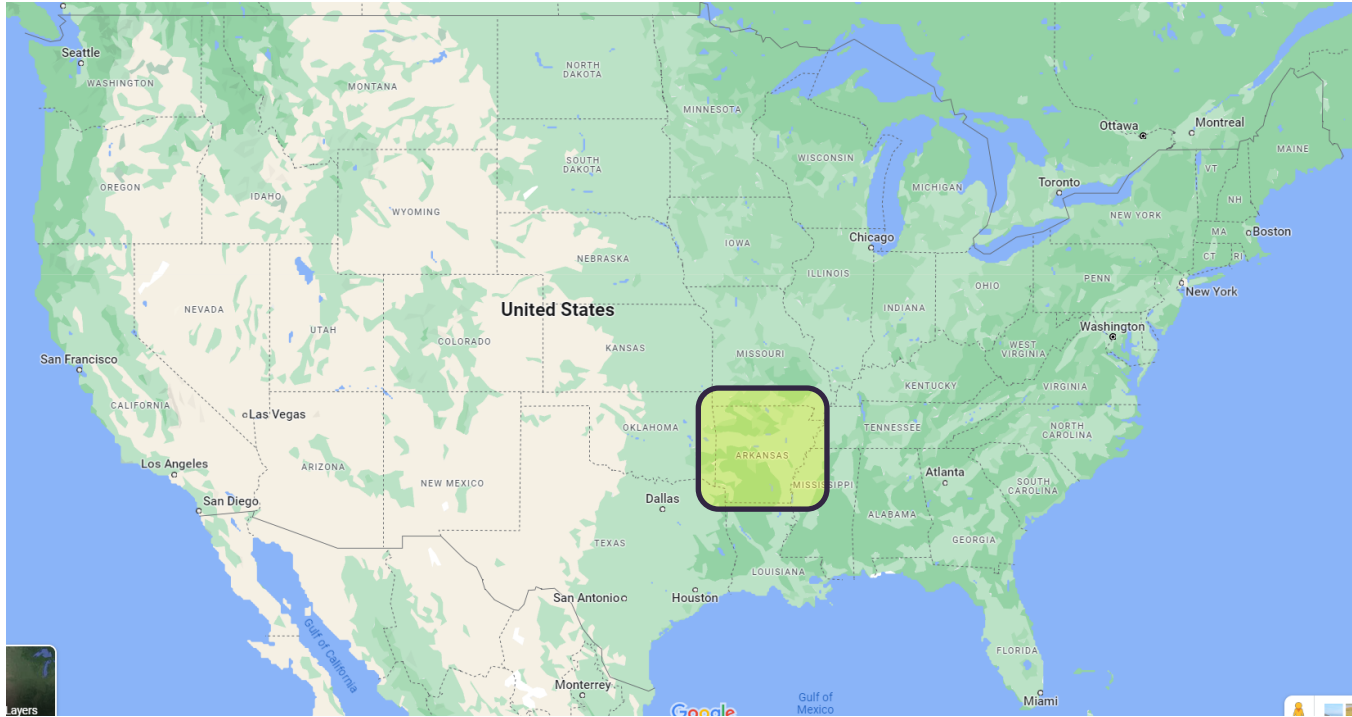

Project Location

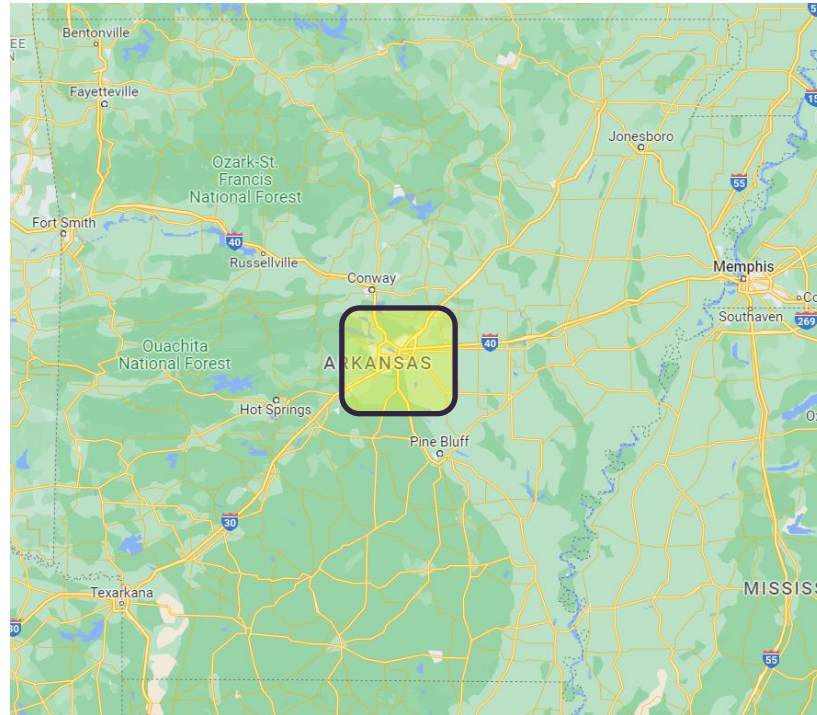

Project Location

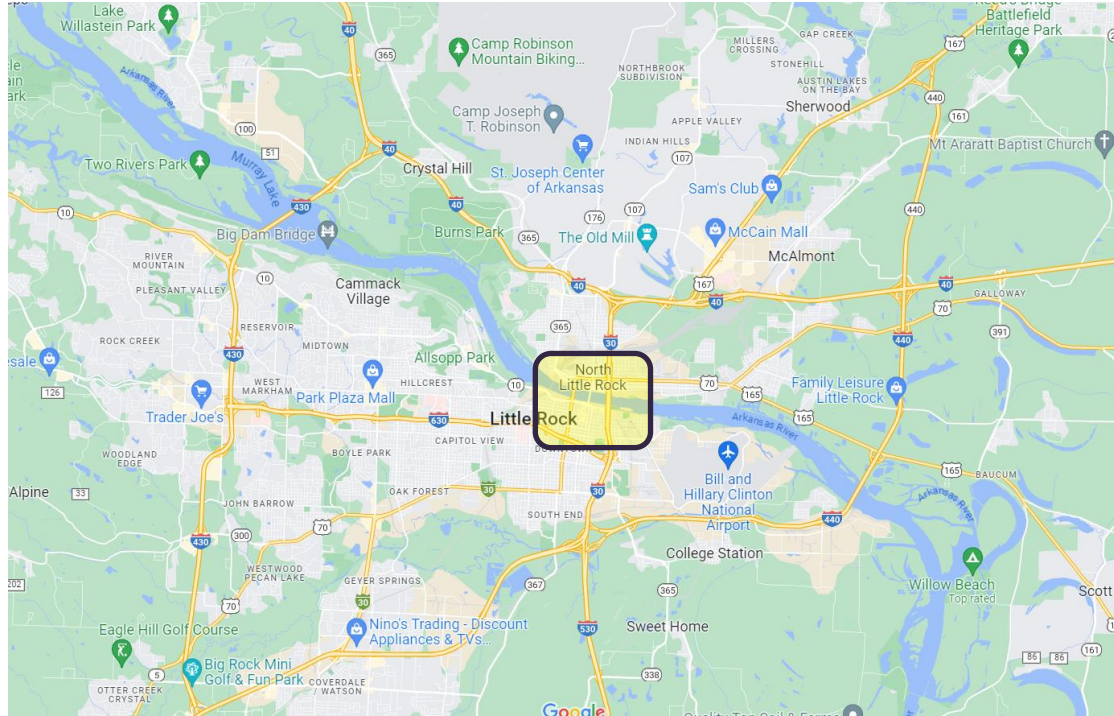

Project Location

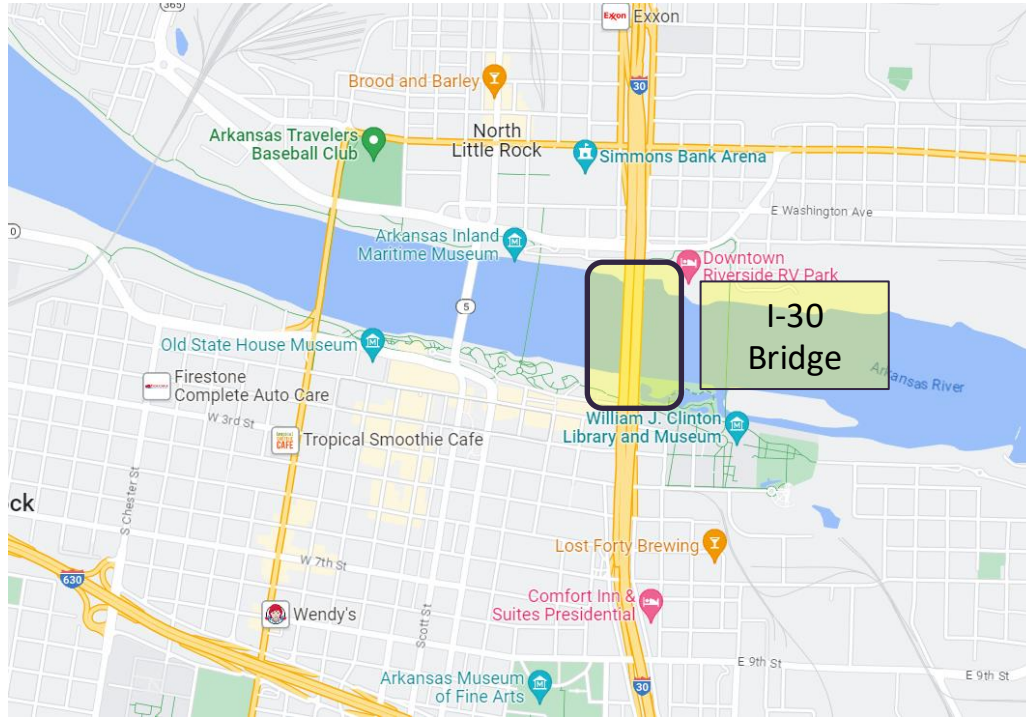

Project Team

- Owner: Arkansas Department of Transportation
- Engineer of Record: Burns & McDonnell/HDR
- Contractor: Kiewit Massman Construction
- Demolition Engineer: Genesis Structures

Project Timeline

- Original Design Complete: 1958
- Contract Awarded: 2019
- Begin Construction: 2020
- Demo Design Plans Complete: May 2022
- Demo Complete: June 2023

Main Span Bridge Elevation

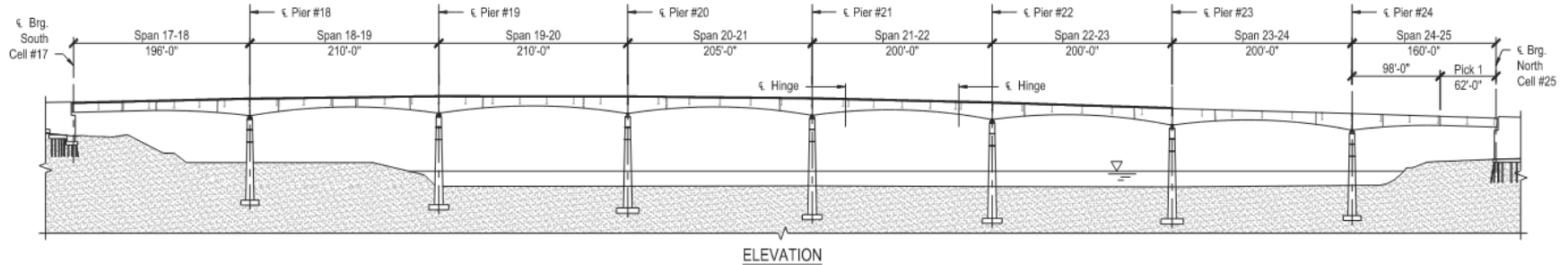

Typical Cross Section

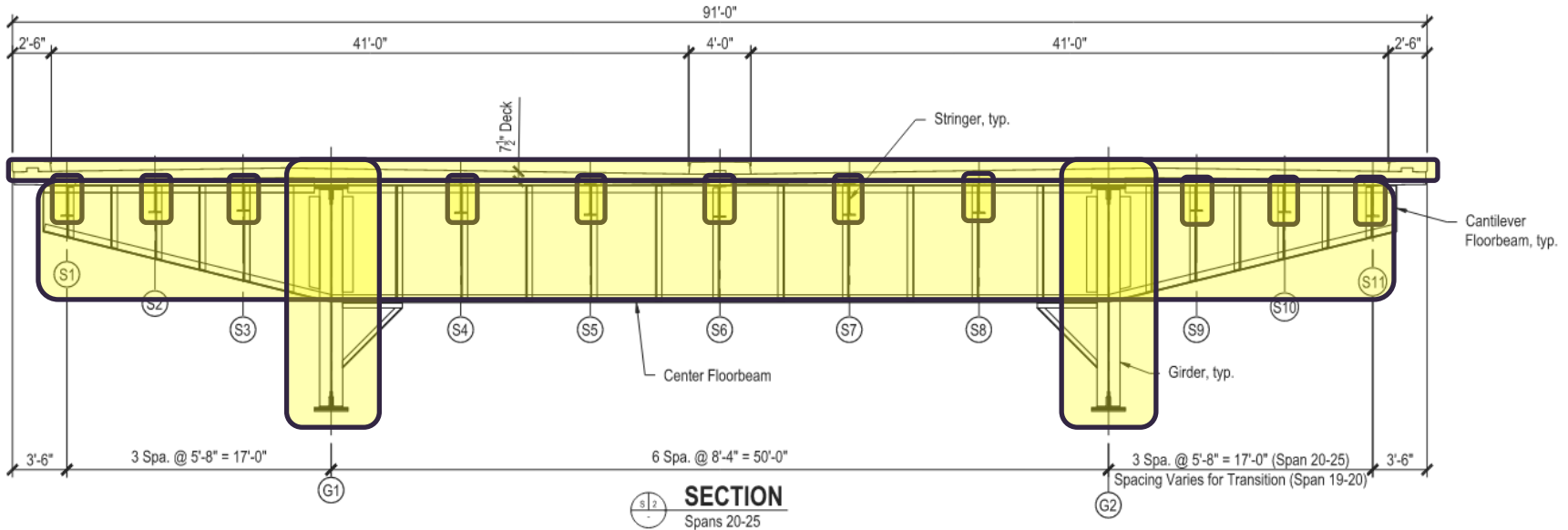

Typical Cross Section



Main Span Bridge Elevation



30 Crossing construction, Little Rock, Arkansas. September 26, 2020. ©David Hoge

IML14501.arw

Photo Credit:
David Hoge

Presentation Outline

- Project Introduction
- **Pre-Demolition Activities**
- Deck & Misc Steel Removal
- Girder Removal
- Current Status

Pre-Demolition Activities

- New EB Bridge Construction
- Corbel Construction
 - Pier Bracket Vertical Support
- Girder Bracing
 - Lateral Torsion Buckling (LTB)

New Bridge Construction Photo



New Bridge Construction Photo



Cast-in-Place Corbel

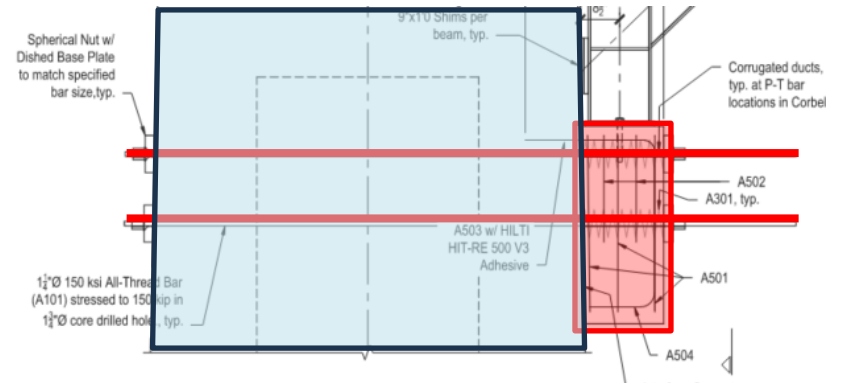
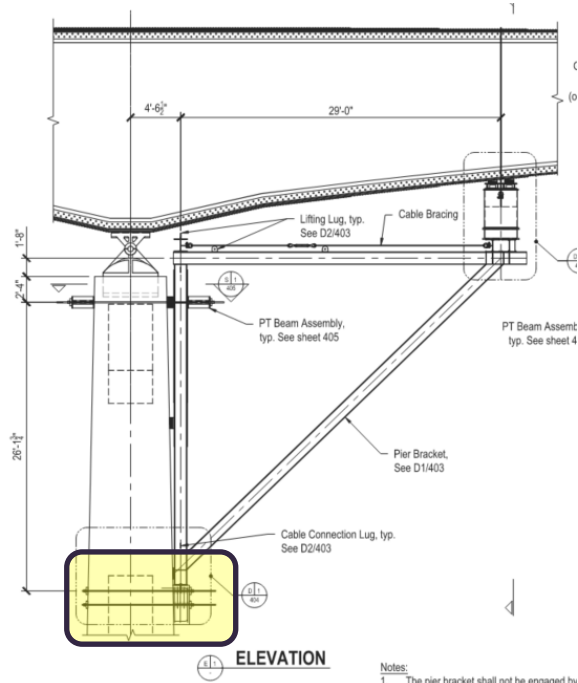

Corbel Post Tensioning



Corbel



Girder LTB Bracing

- Girder near dead load contraflexure point
 - Original demand minimal
 - No flange cover plates, only flange angles
- Negative moment increase during the deck removal operation
 - Bottom flange in compression
- Opted to increase capacity as opposed to decrease demands

Girder LTB Bracing

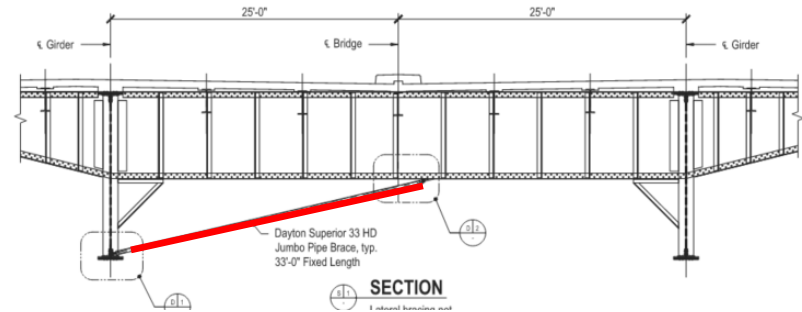
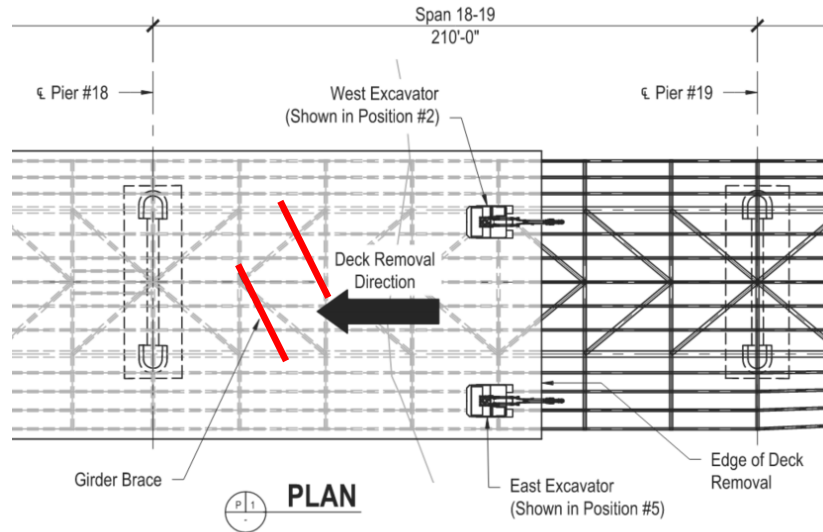

Girder LTB Bracing



Presentation Outline

- Project Introduction
- Pre-Demolition Activities
- **Deck & Misc Steel Removal**
- Girder Removal
- Current Status

Deck Removal

CAT

326F

Hydraulic Excavator

Notes:

1. Excavator Operating Weight = 58,801 lbs (including hammer)
2. Impact Hammer Attachment Weight = 3,800 lbs
3. Shearing Tool Attachment Weight = 3,800 lbs



Deck Removal



Deck Removal



Pre-Stripping Stringers



Pre-Stripping Cantilever Floorbeam

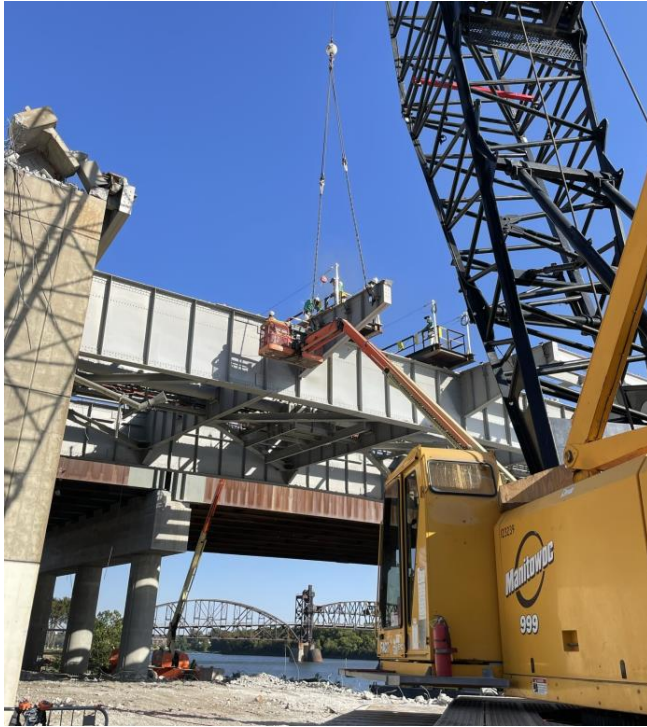

Presentation Outline

- Project Introduction
- Pre-Demolition Activities
- Deck & Misc Steel Removal
- **Girder Removal**
- Current Status

Presentation Outline

- Project Introduction
- Pre-Demolition Activities
- Deck & Misc Steel Removal
- **Girder Removal – Temporary Works**
- Current Status

Girder Removal - Temporary Works

- Single Girder Pick - Beam Clamp
- Double Girder Pick - Custom Lifting Lugs
- Pier Brackets w/ Corbel
- Strong Backs
- Longitudinal Bearing Restraint
- Falsework
- Final Girder Brace

Girder Removal

Single
Girder
Pick

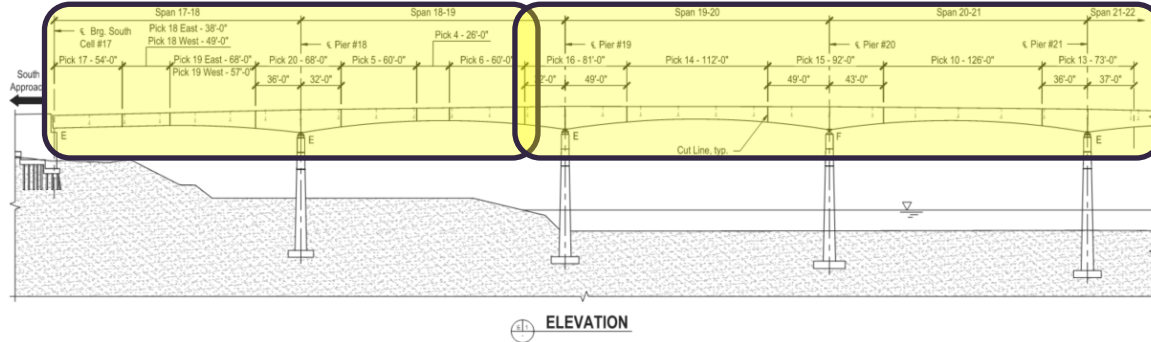

Double
Girder
Pick

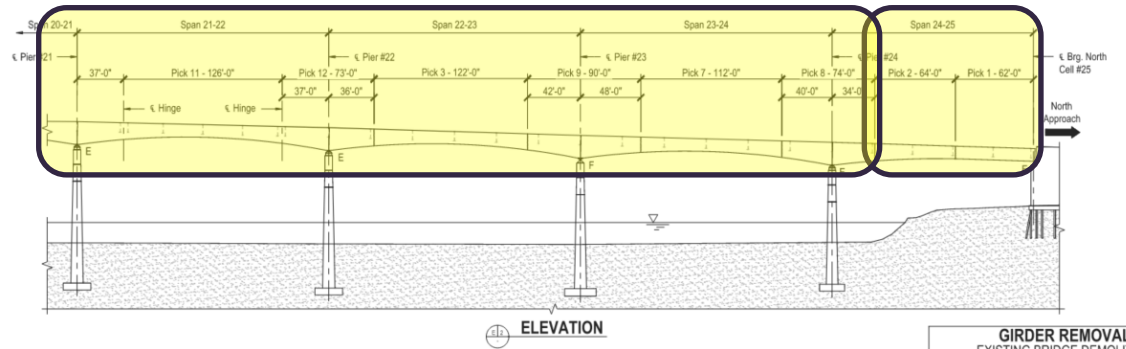

Girder Removal Stage 1

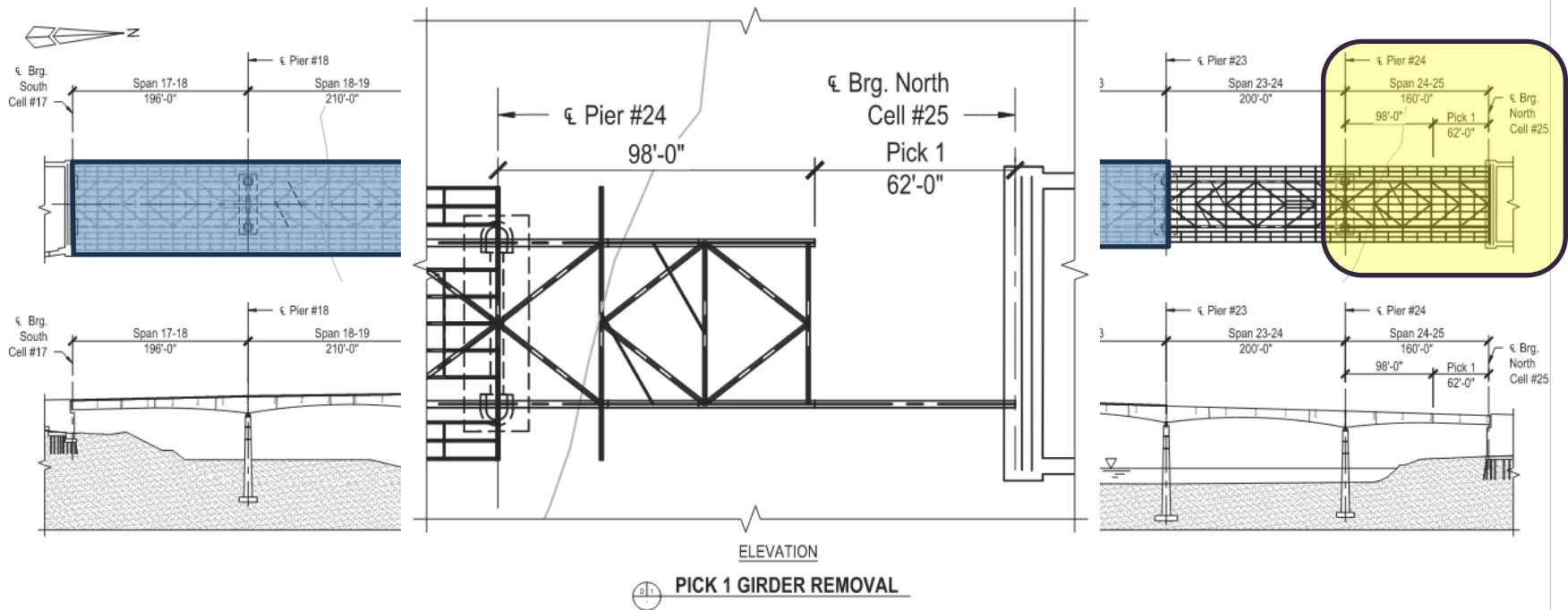

Girder Removal Stage 1



Girder Removal Stage 2

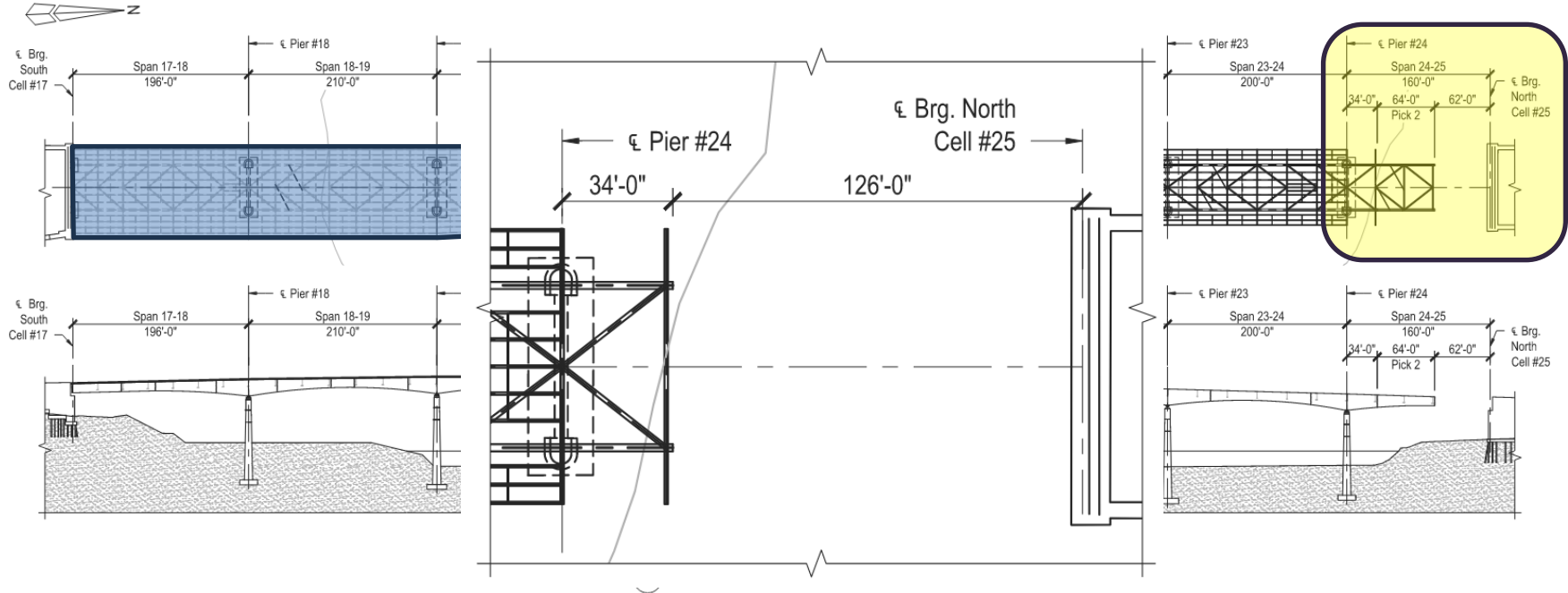

Girder Removal Stage 2



Girder Removal Stage 3

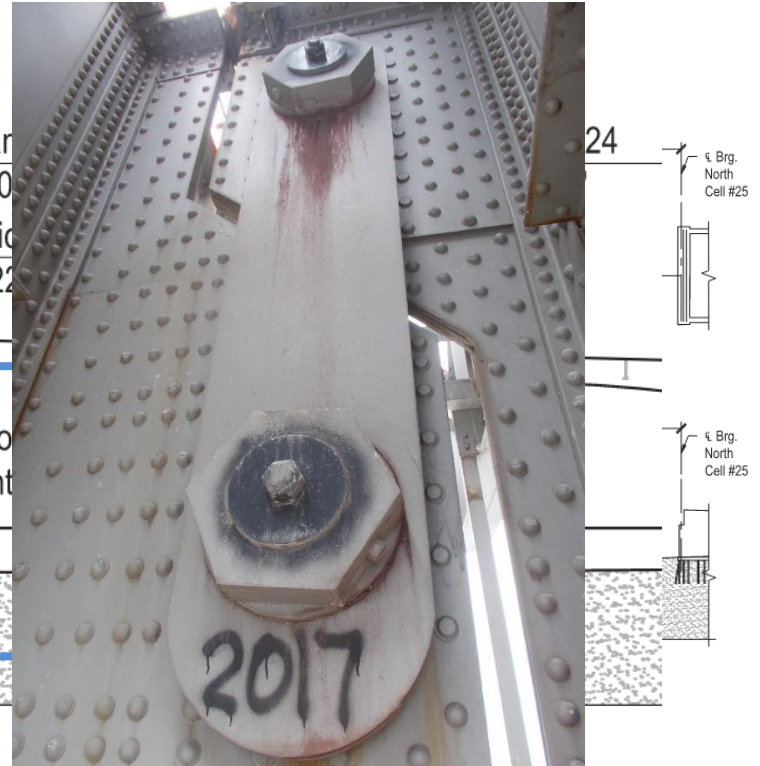
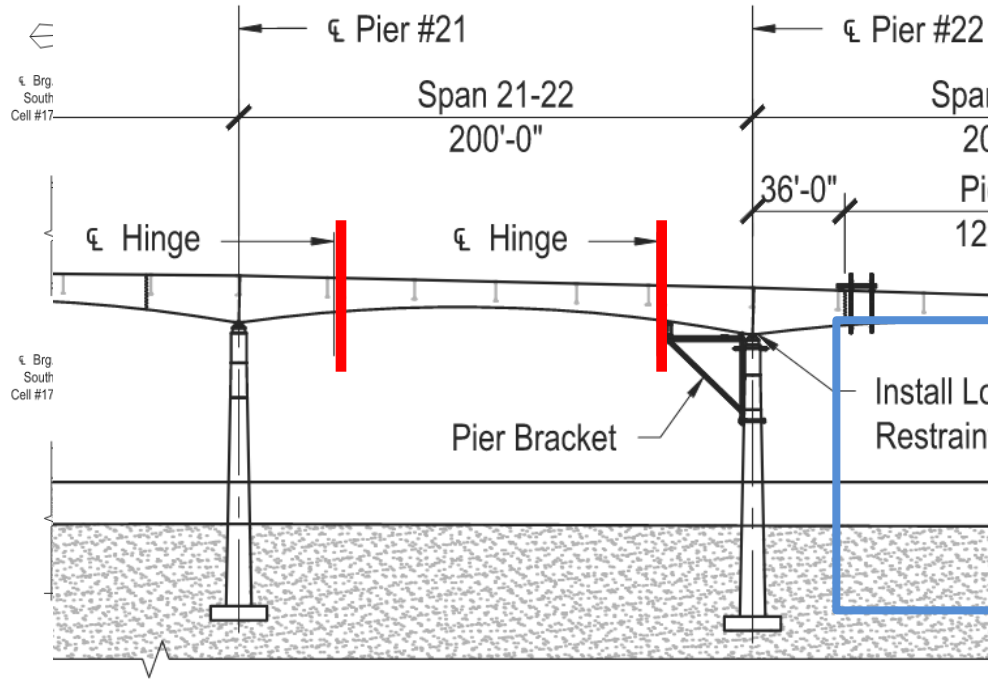

Pier Bracket

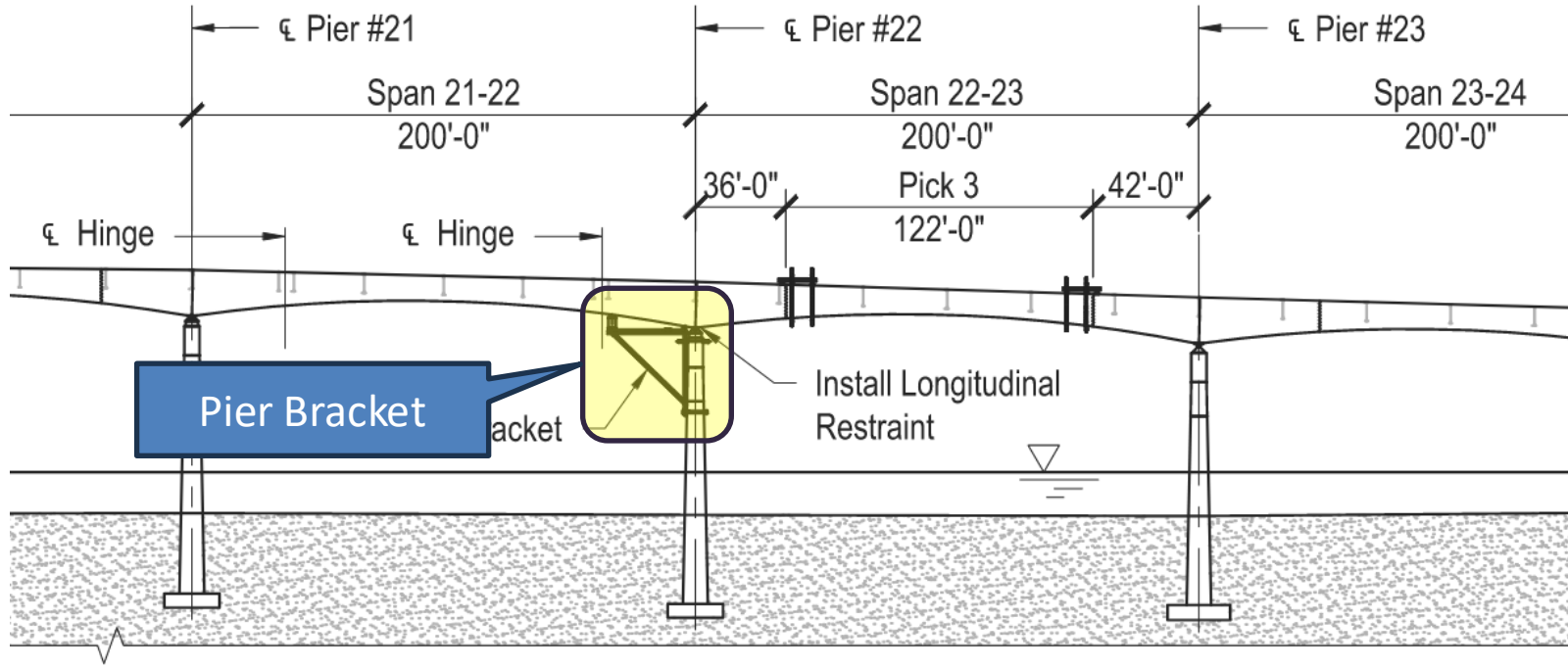

Pier Bracket

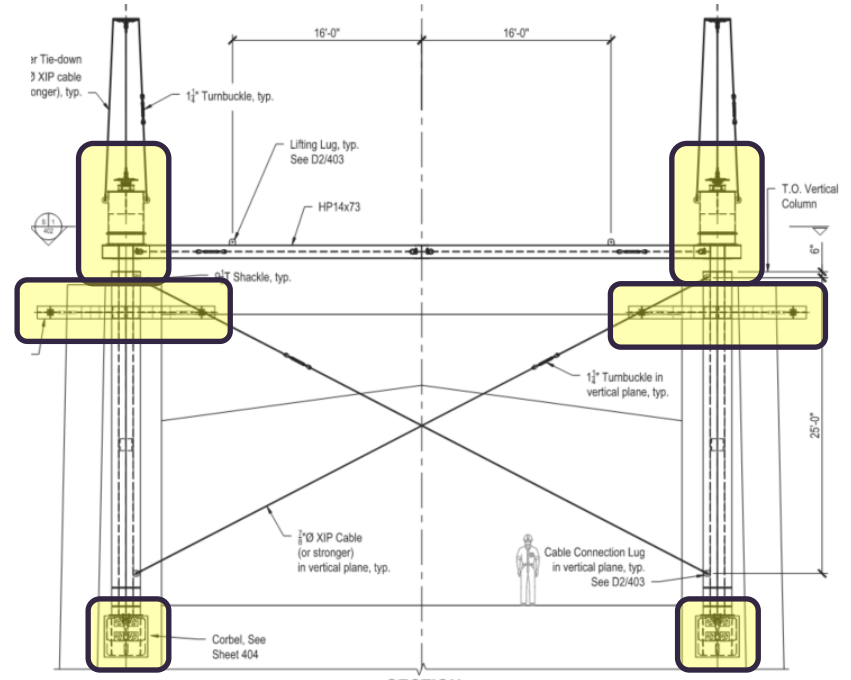
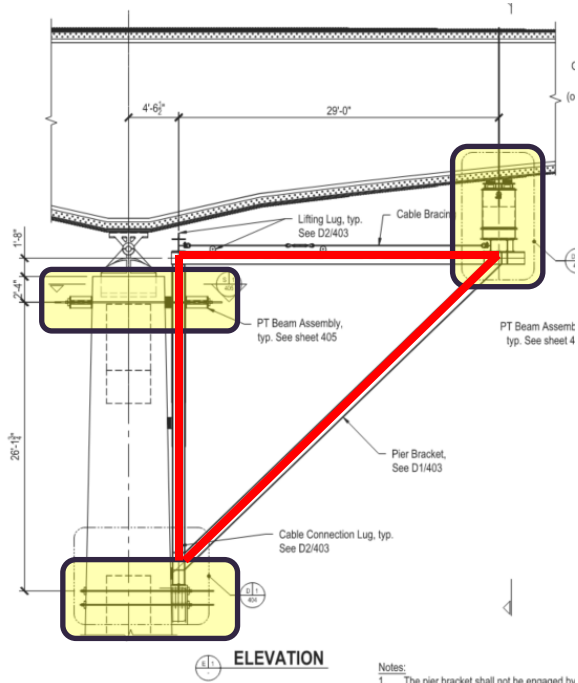

Pier Bracket

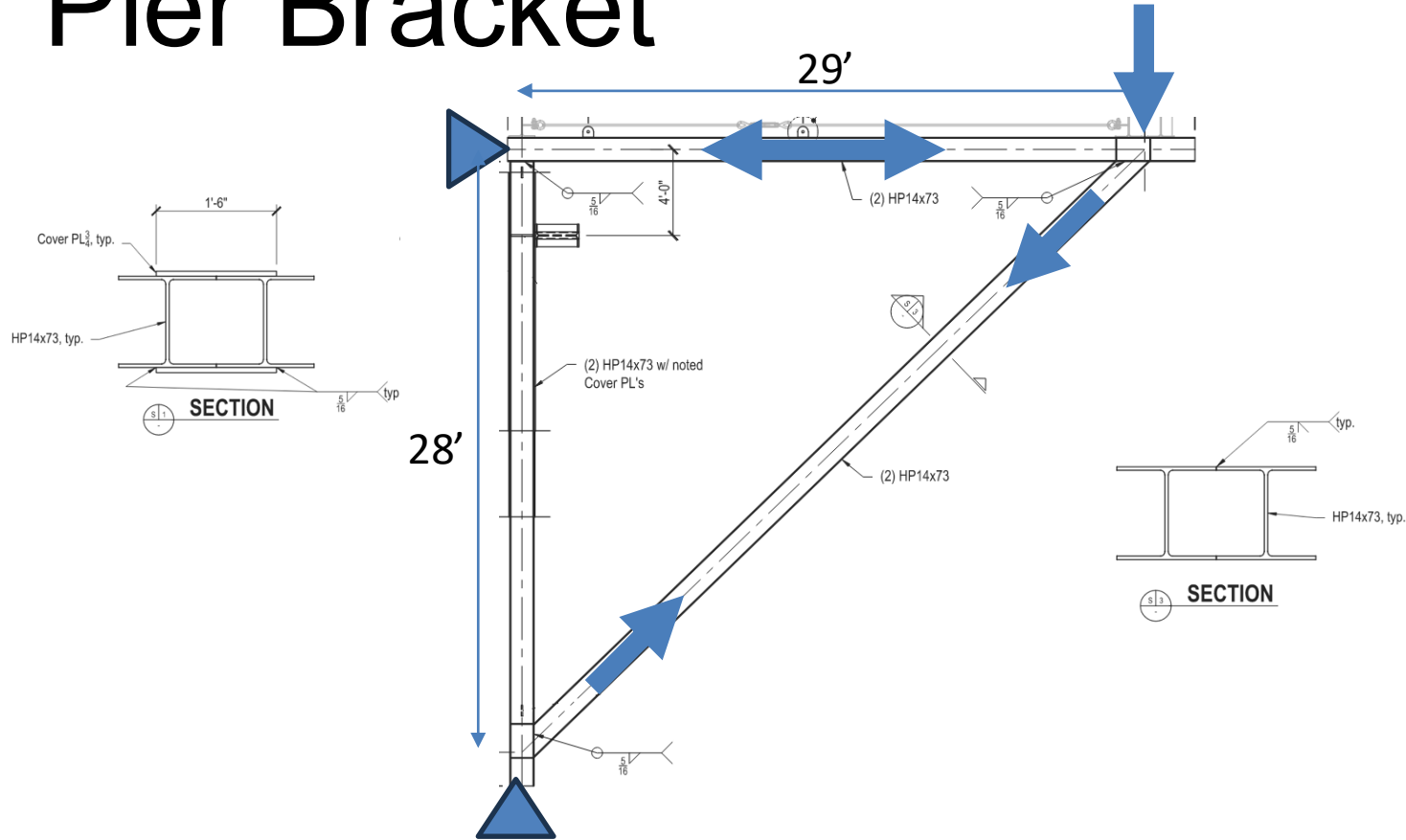

Pier Bracket – Upper PT Beam

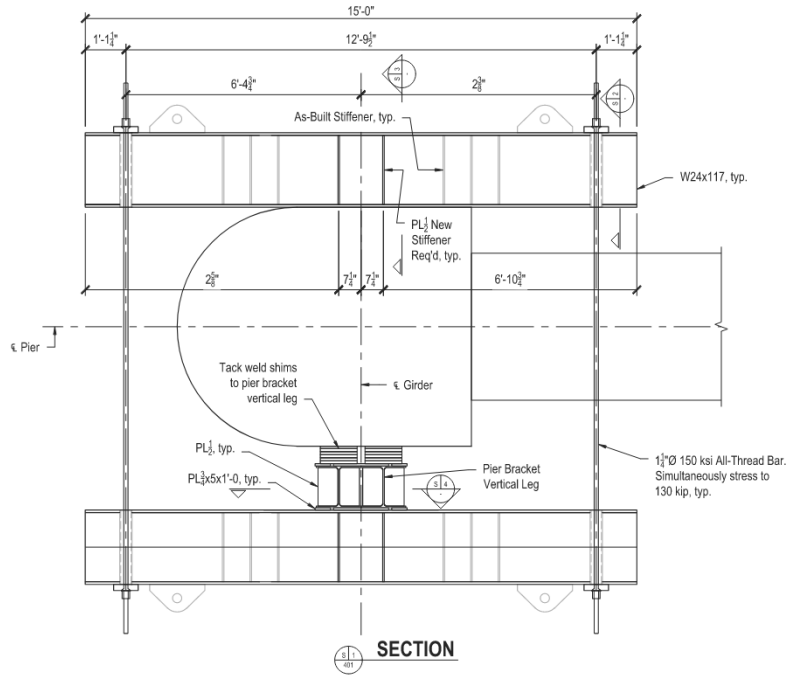

Pier Bracket – Wind Bracing

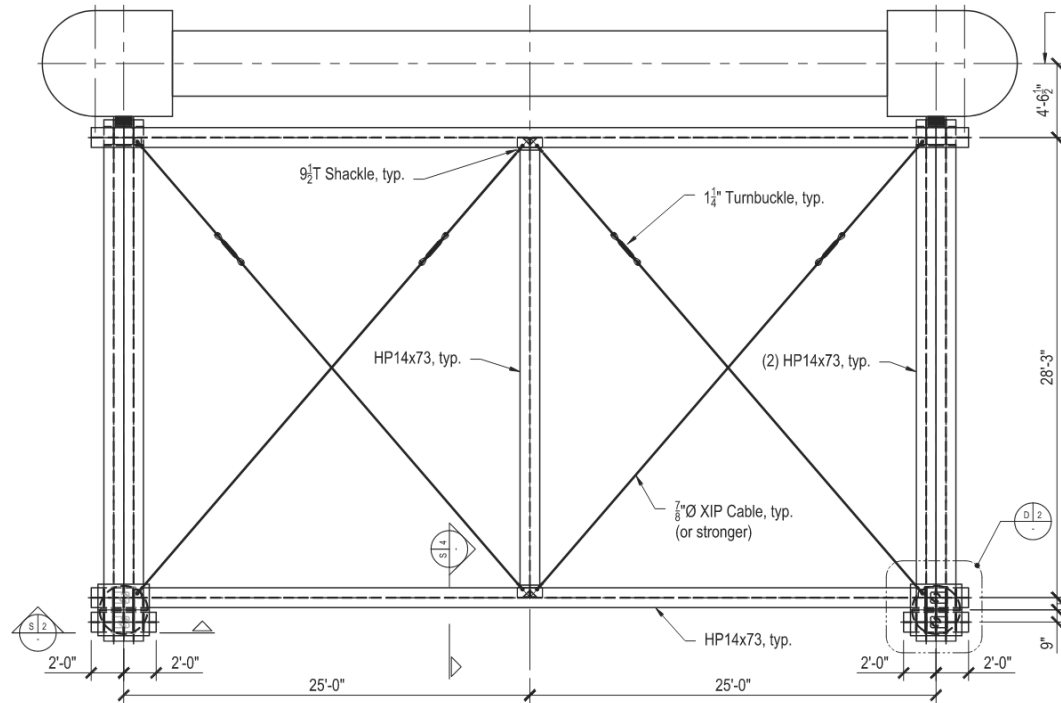

Pier Bracket



Pier Bracket



30 Crossing Construction Pier 24 with pier brackets. Demolition of I-30 bridge, North Little Rock, Arkansas, October 20, 2022. ©David Hogg

M182421.jpg



30 Crossing Construction Pier bracket on P-21. Demolition of I-30 bridge, North Little Rock, Arkansas, October 12, 2022. ©David Hogg

M66099.jpg

Strong Back

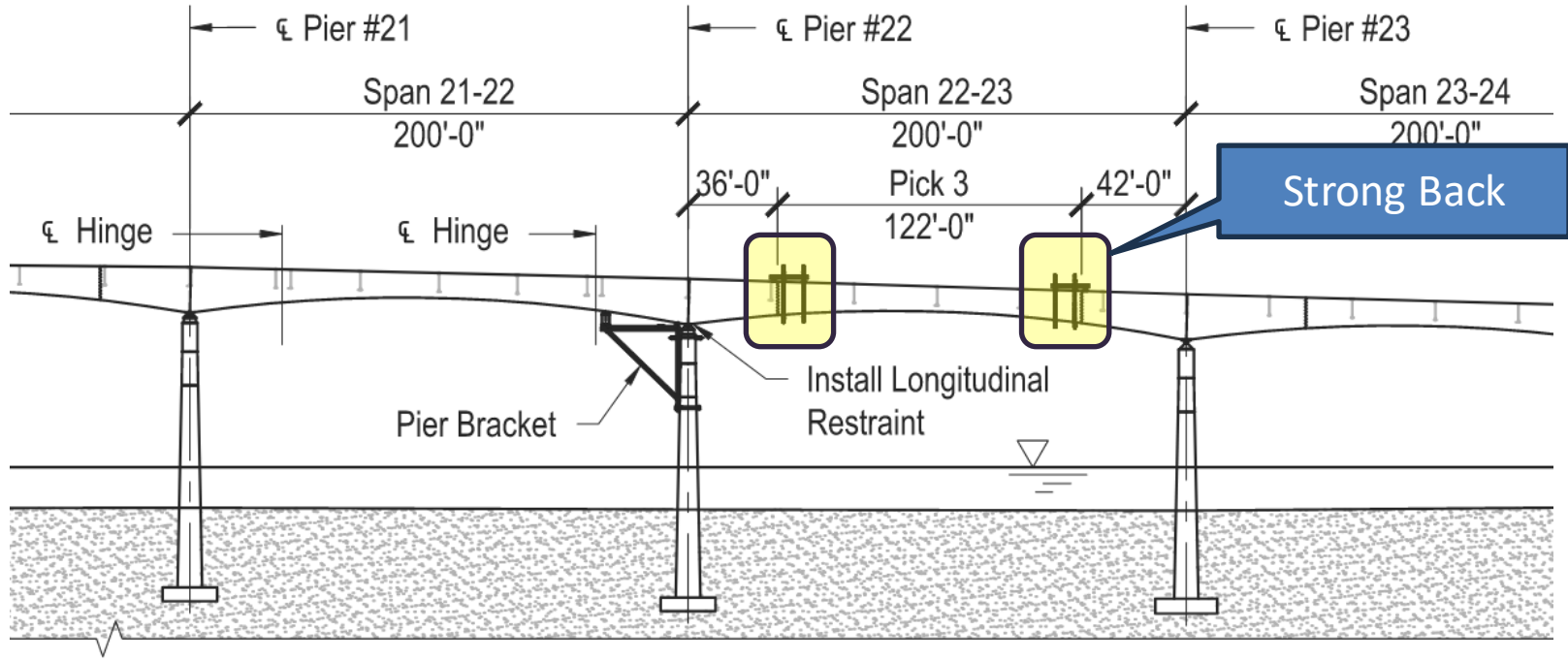

Strong Back

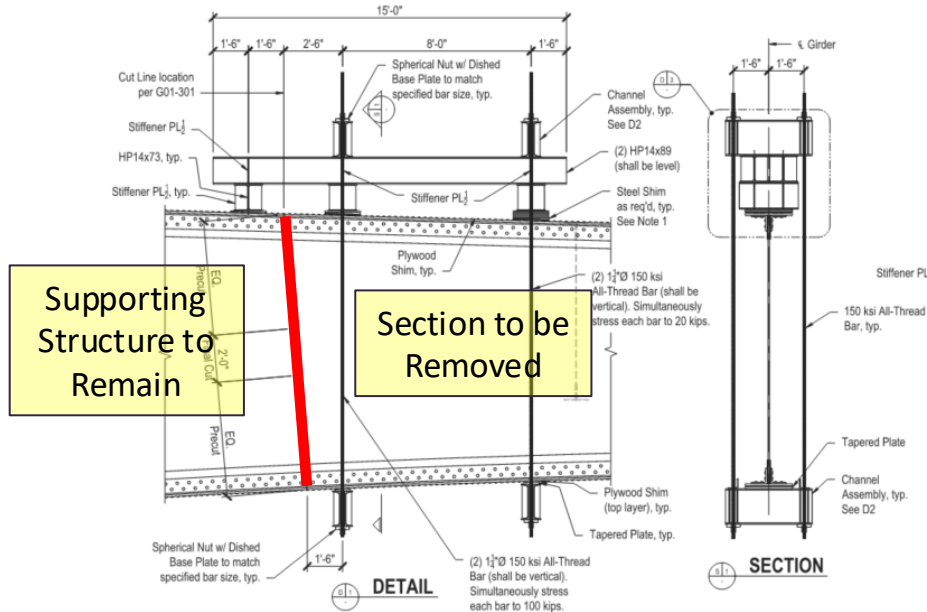

Supporting Structure to Remain

Section to be Removed

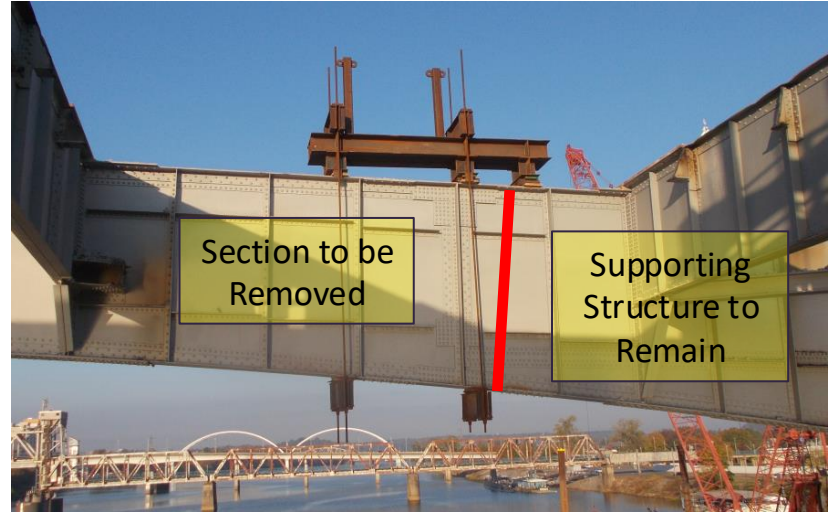

Strong Back



Longitudinal Bearing Restraints

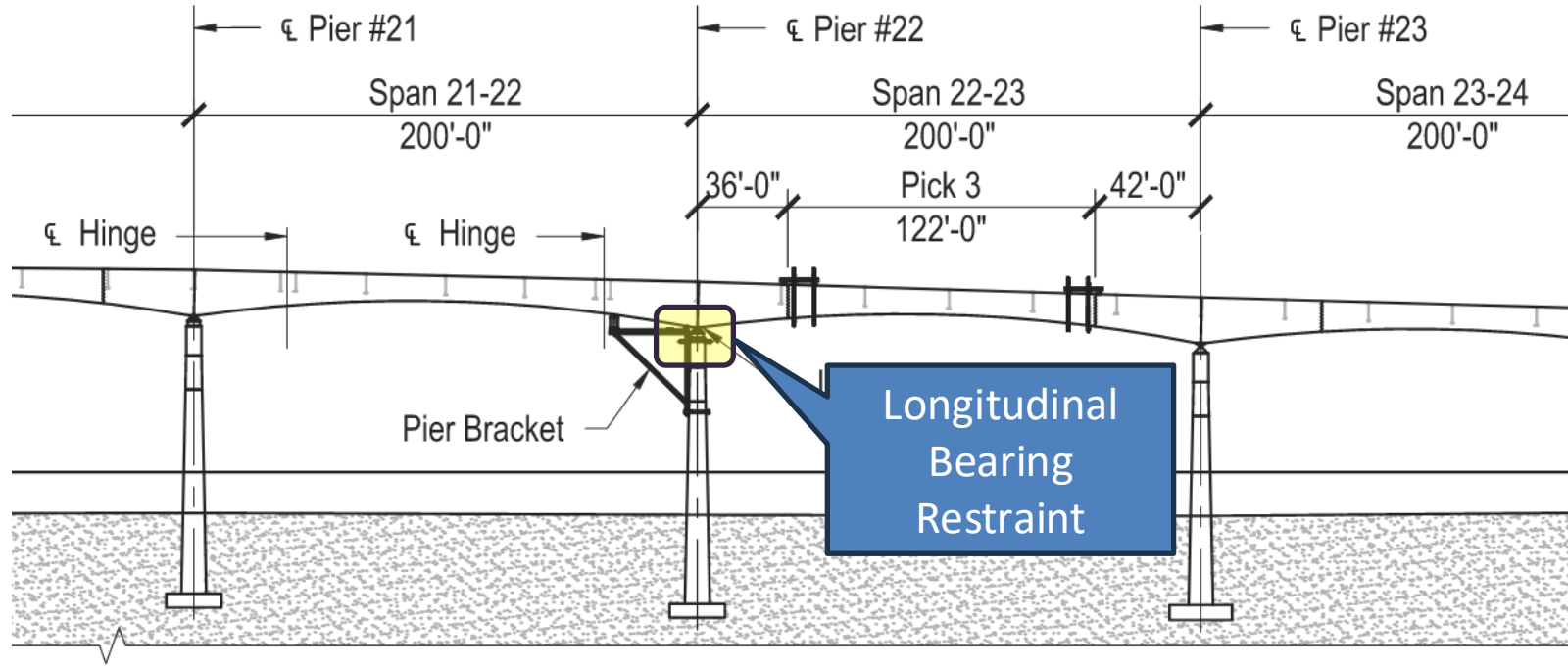

Longitudinal Bearing Restraints



Custom Lifting Lug

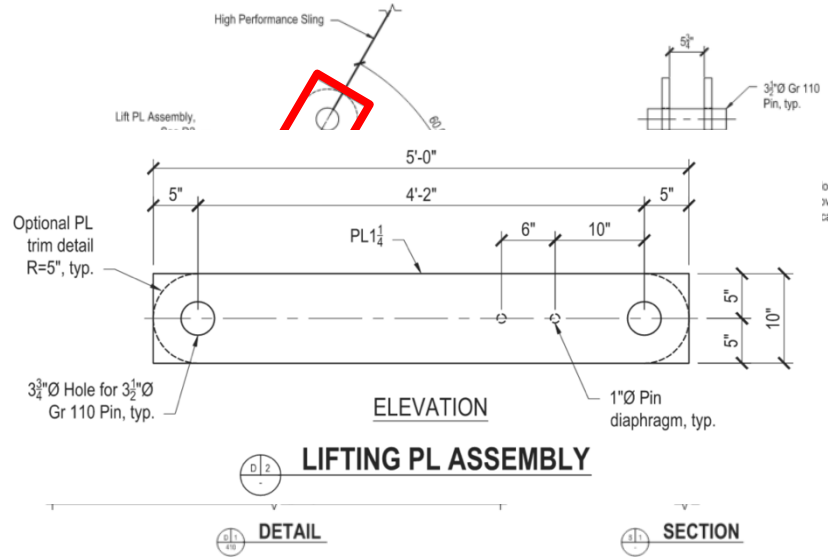
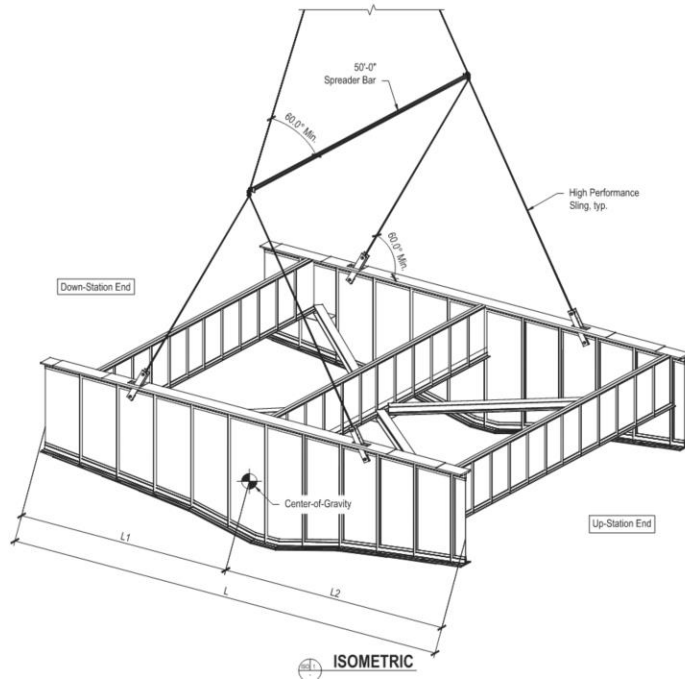

Custom Lifting Lug



Girder Removal Stage 3

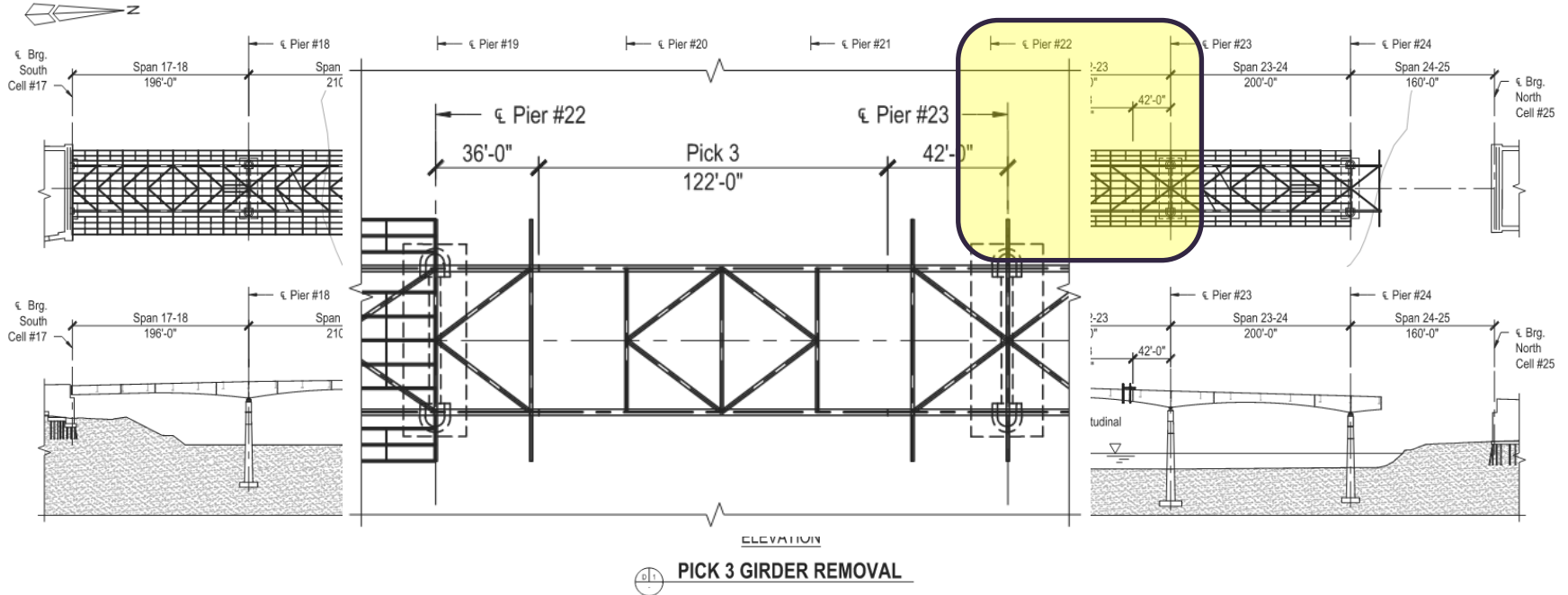

51 PICK 3 GIRDER REMOVAL

Girder Removal Stage 3

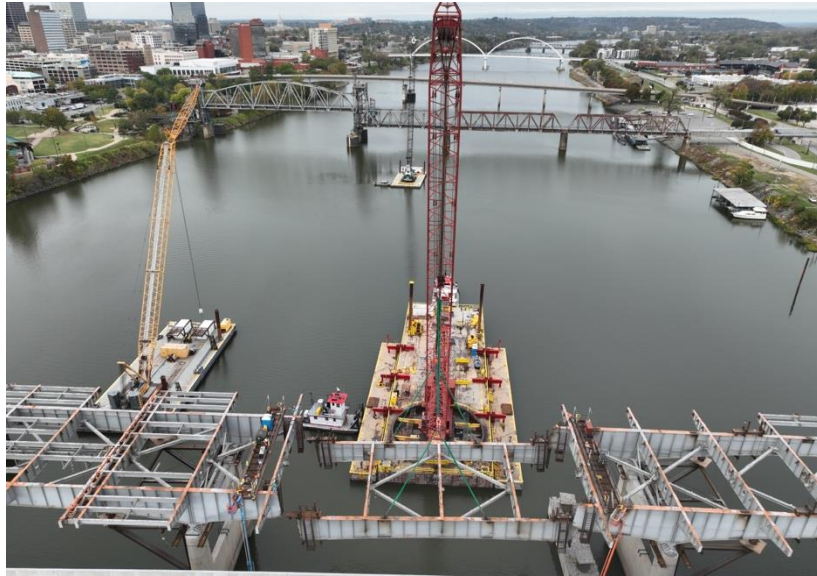

Girder Removal Stage 3



Girder Removal Stage 4

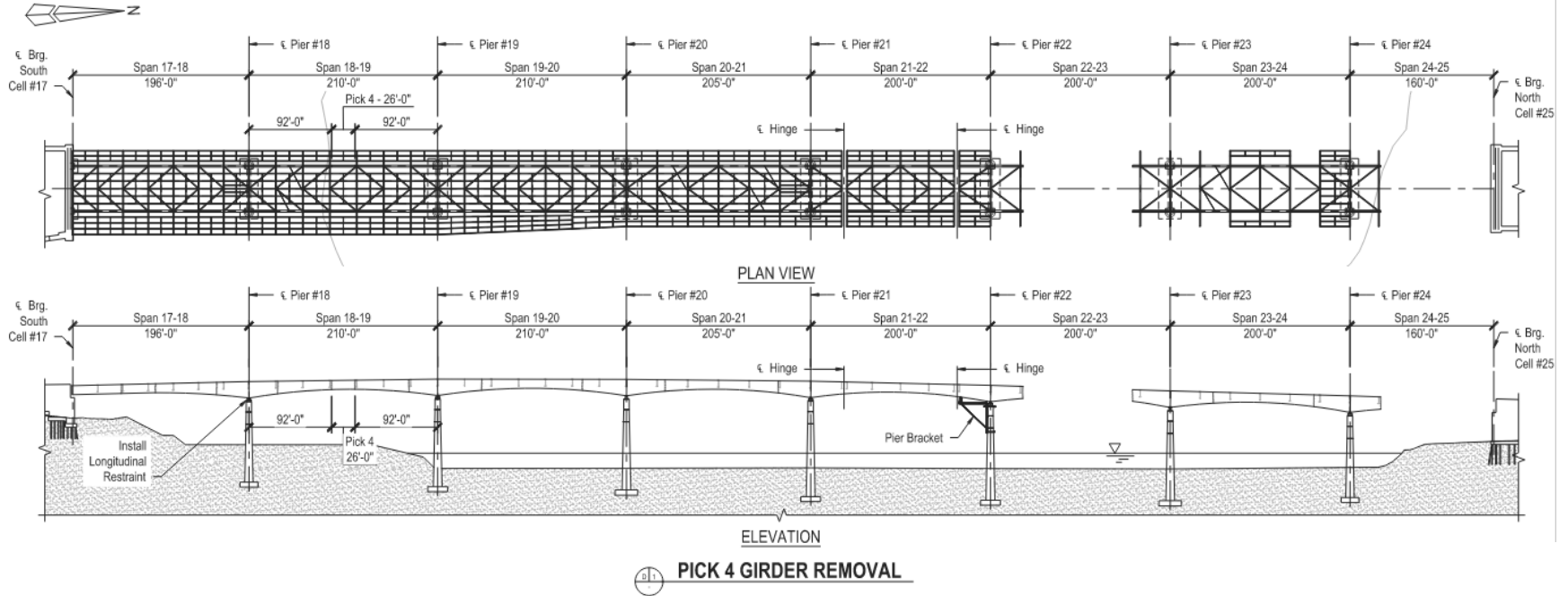

Girder Removal Stage 5

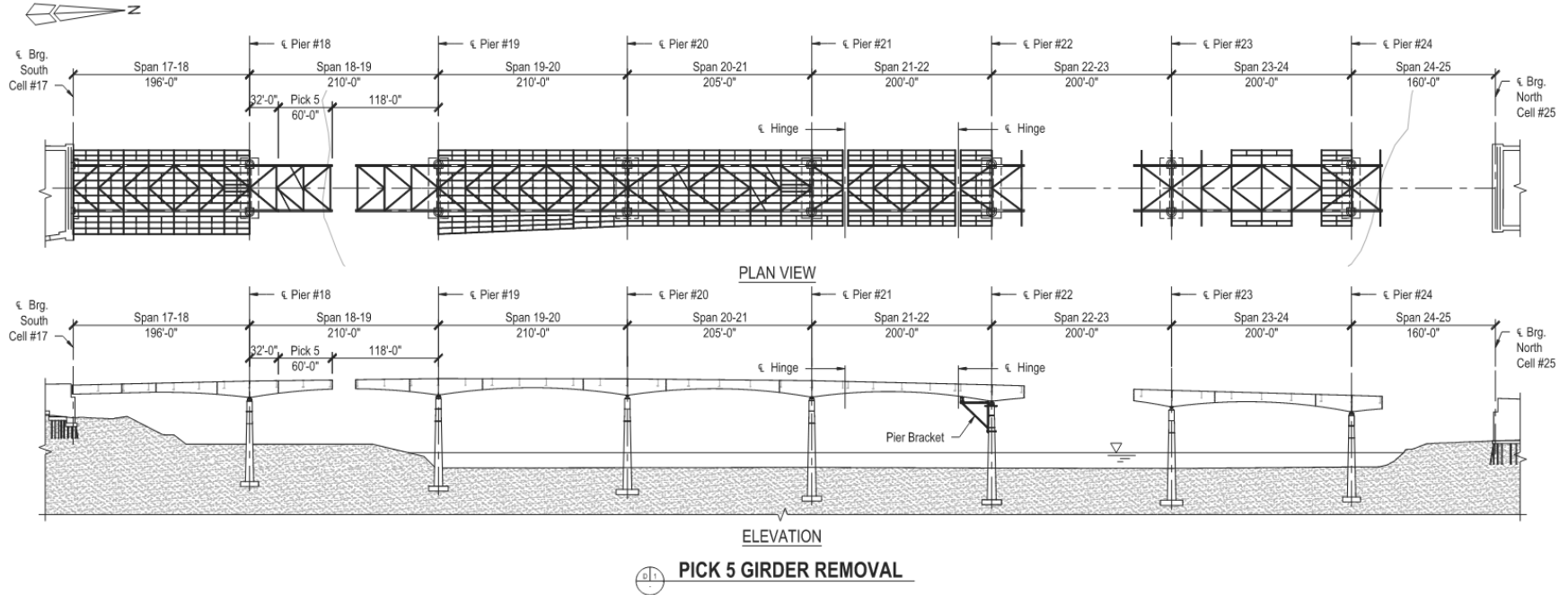

Girder Removal Stage 6

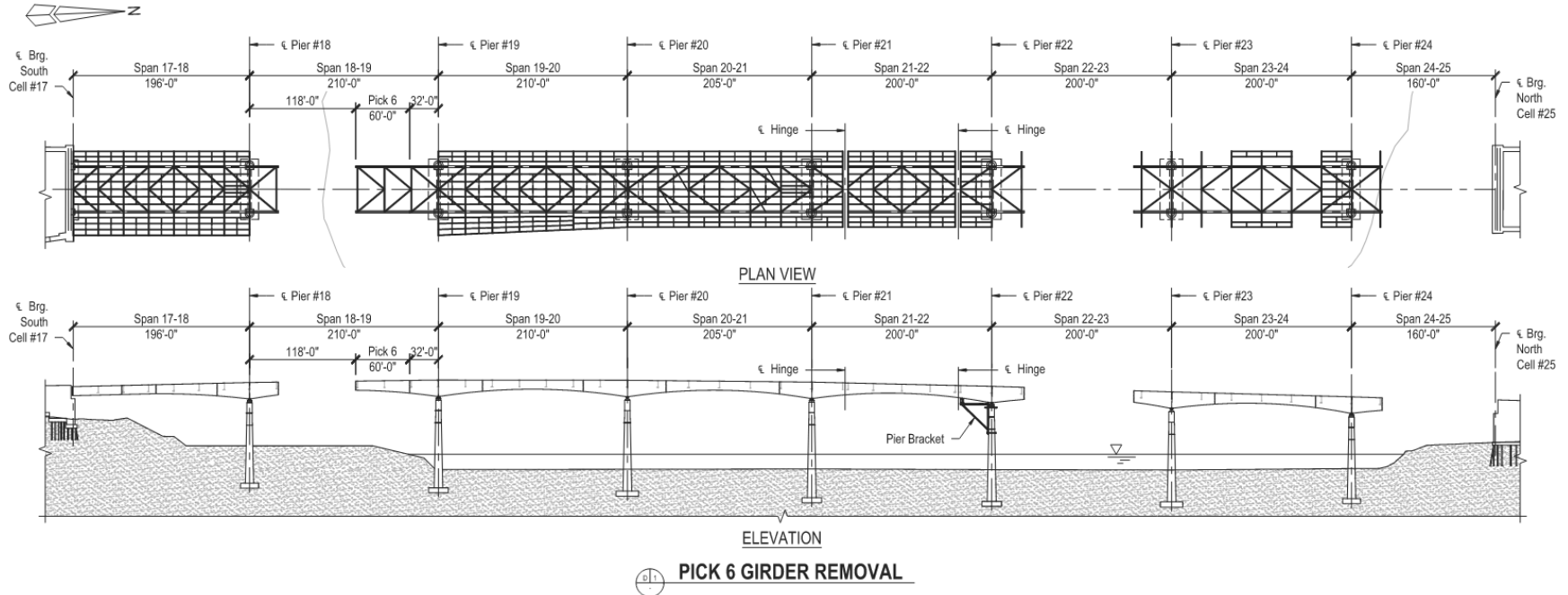

Girder Removal Stage 8

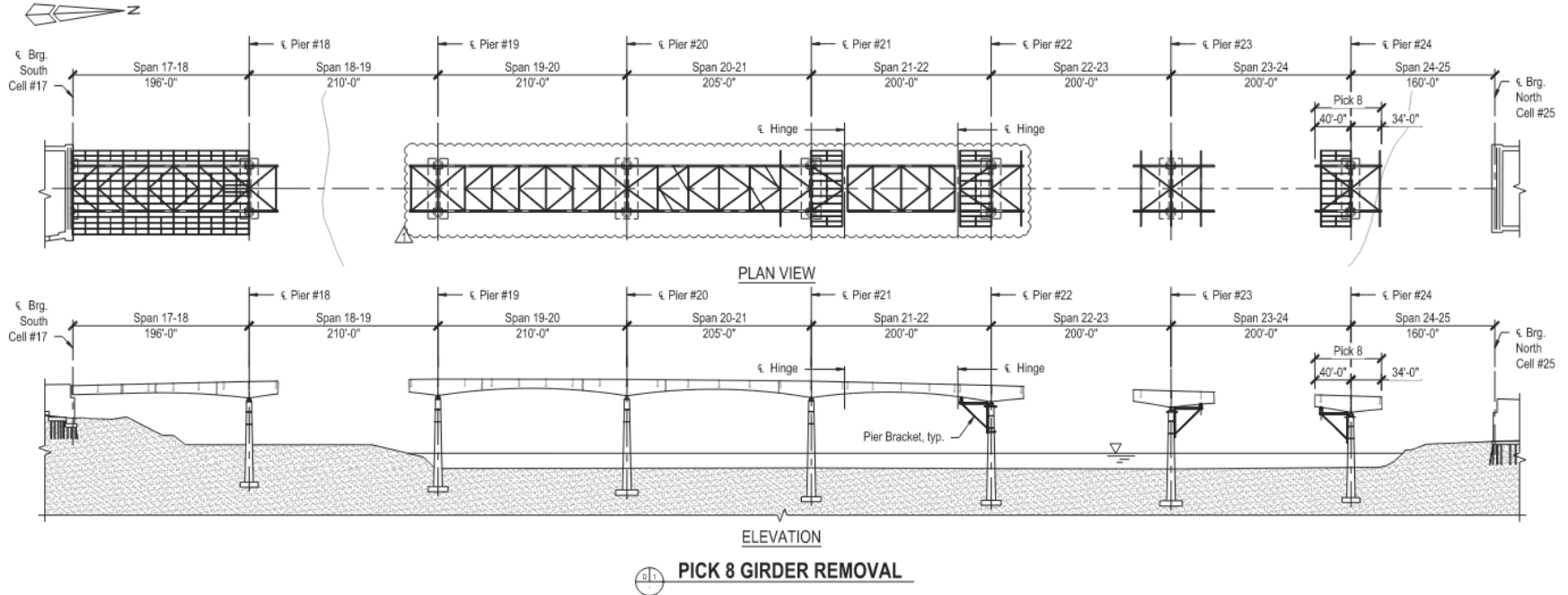

Girder Removal Stage 9

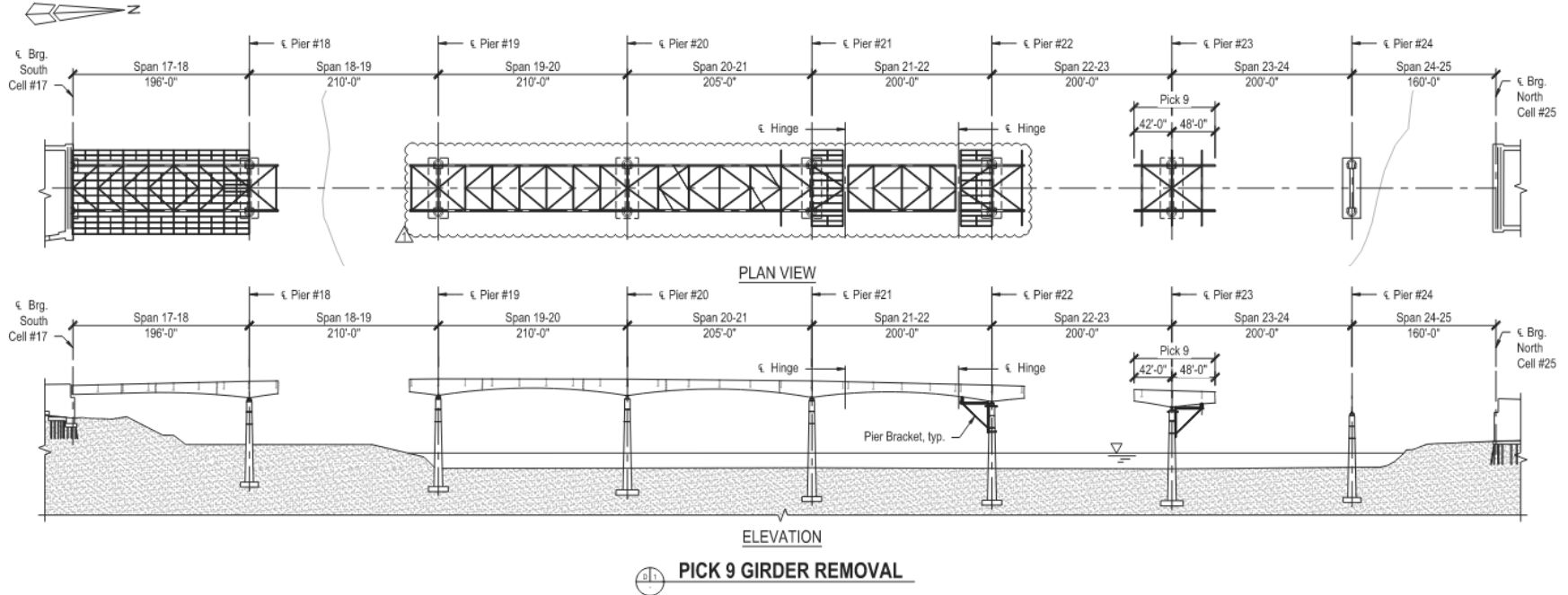

Girder Removal Stage 10

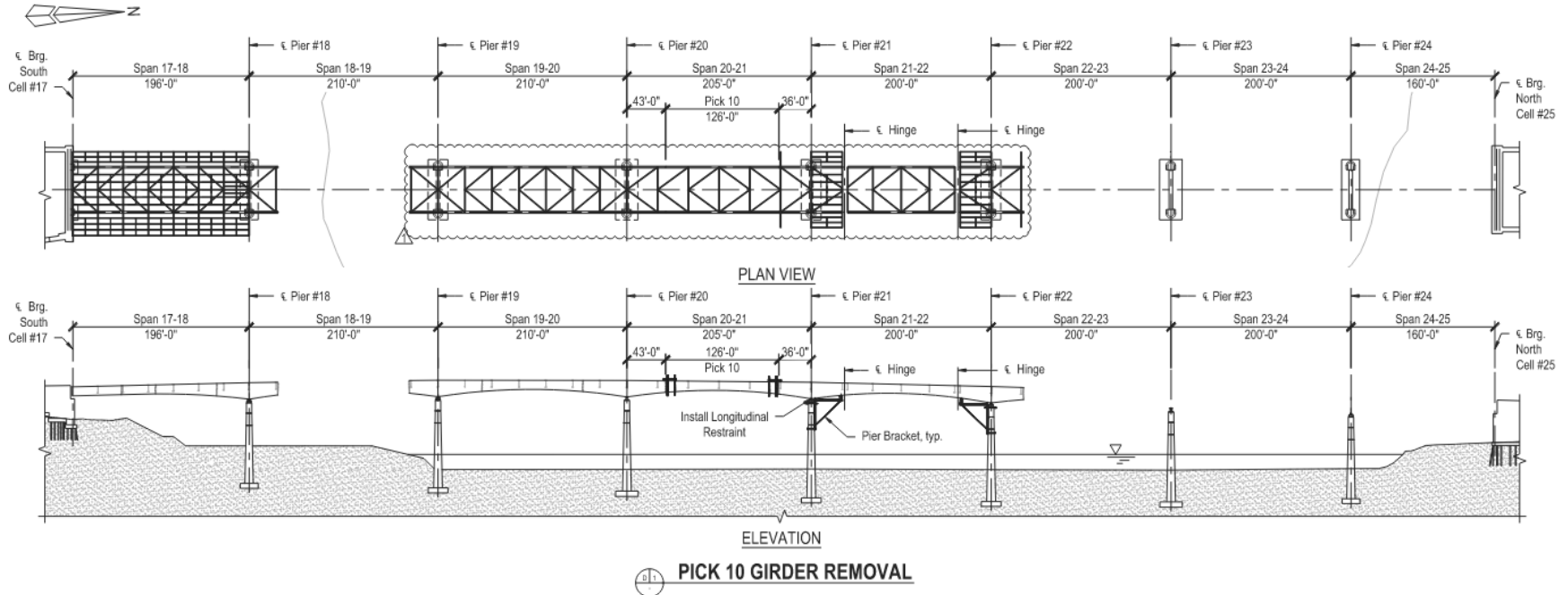

Girder Removal Stage 11

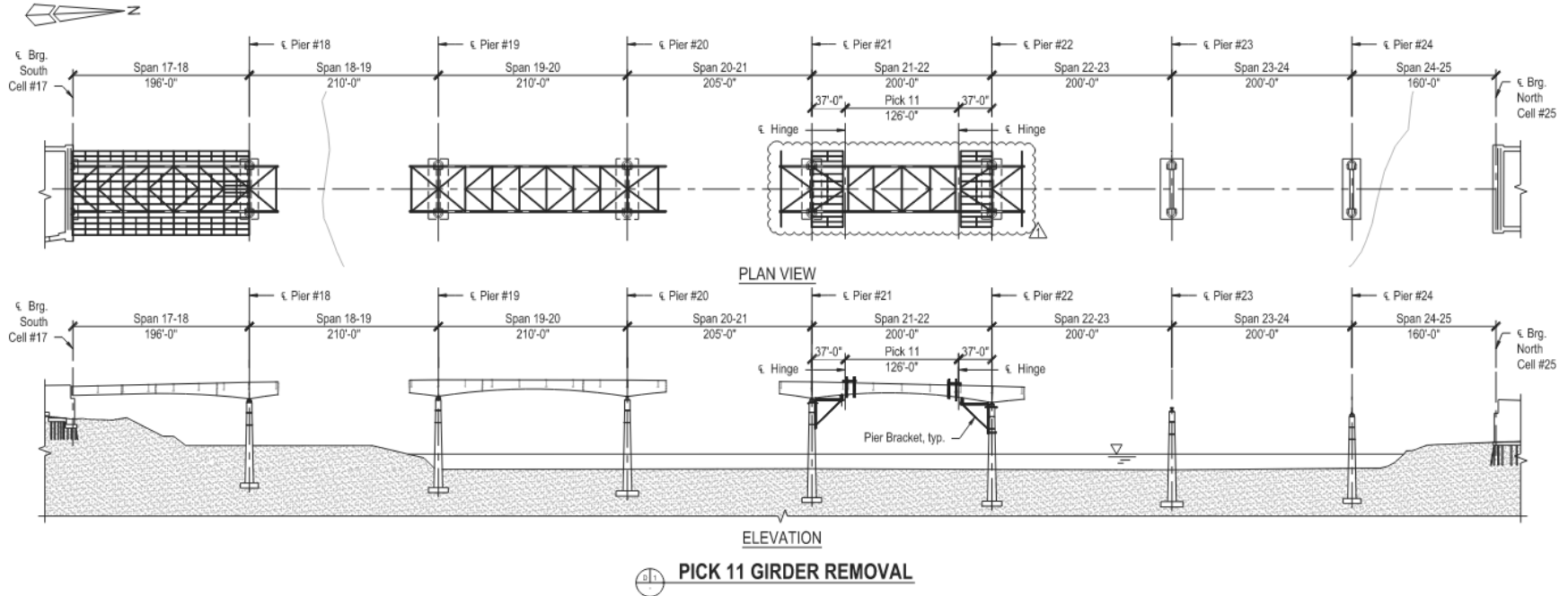

Girder Removal Stage 12

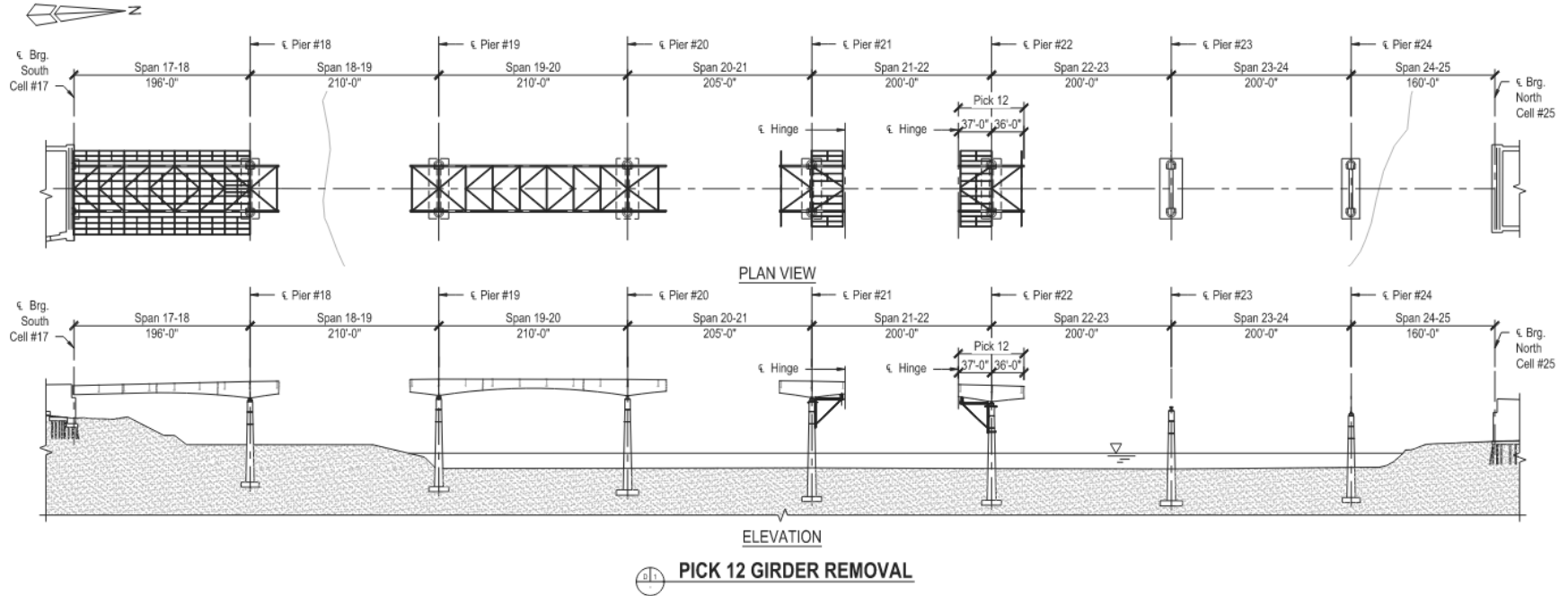

Girder Removal Stage 13

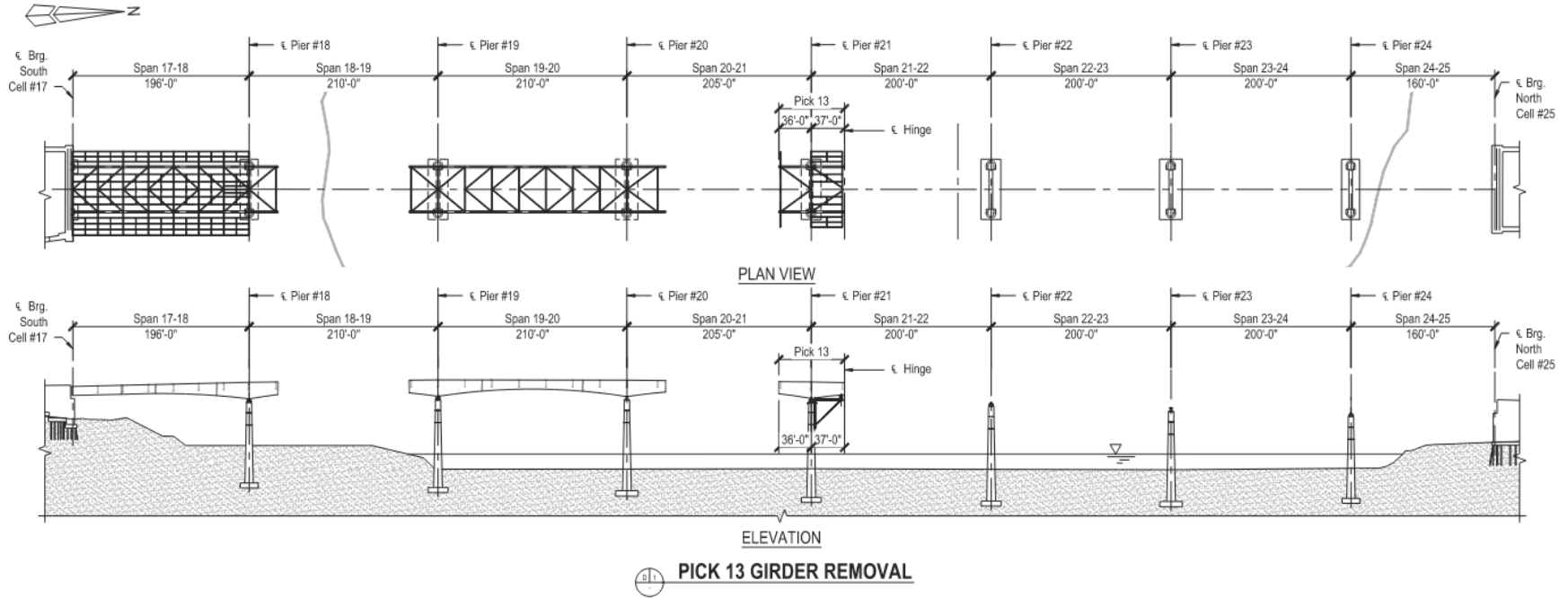

Girder Removal Stage 14

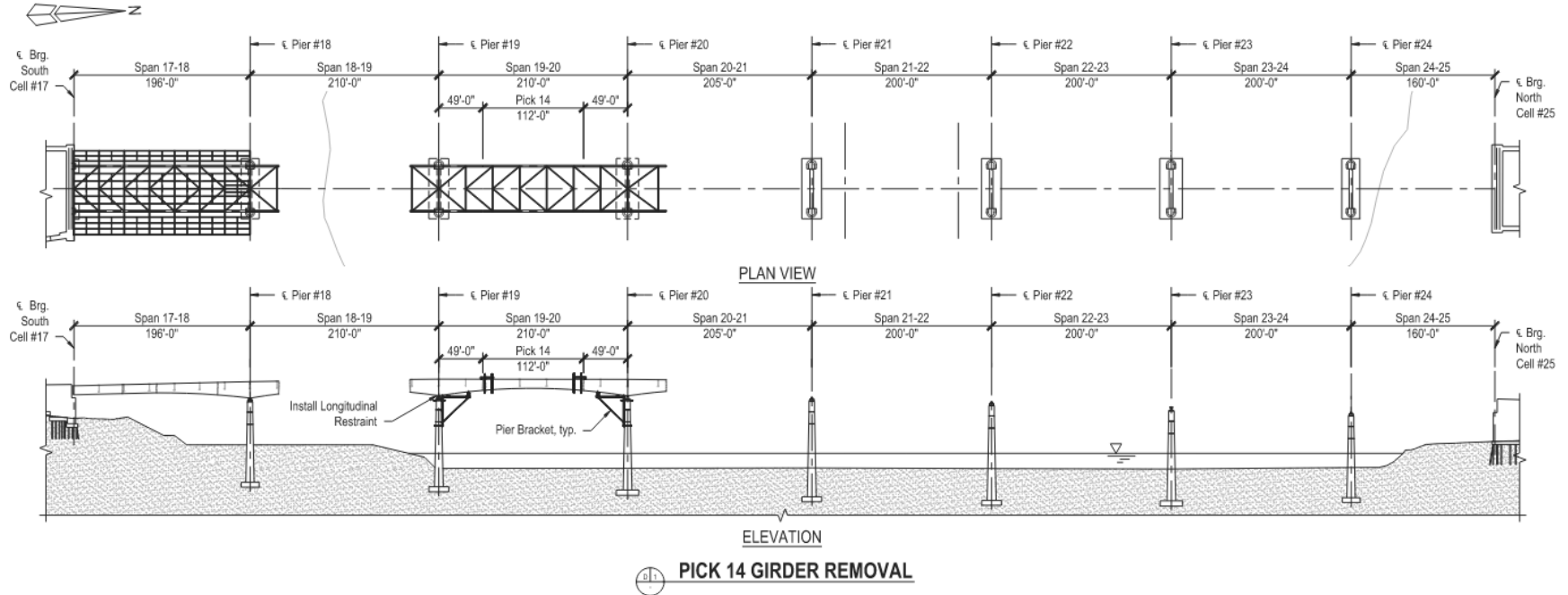

Girder Removal Stage 15

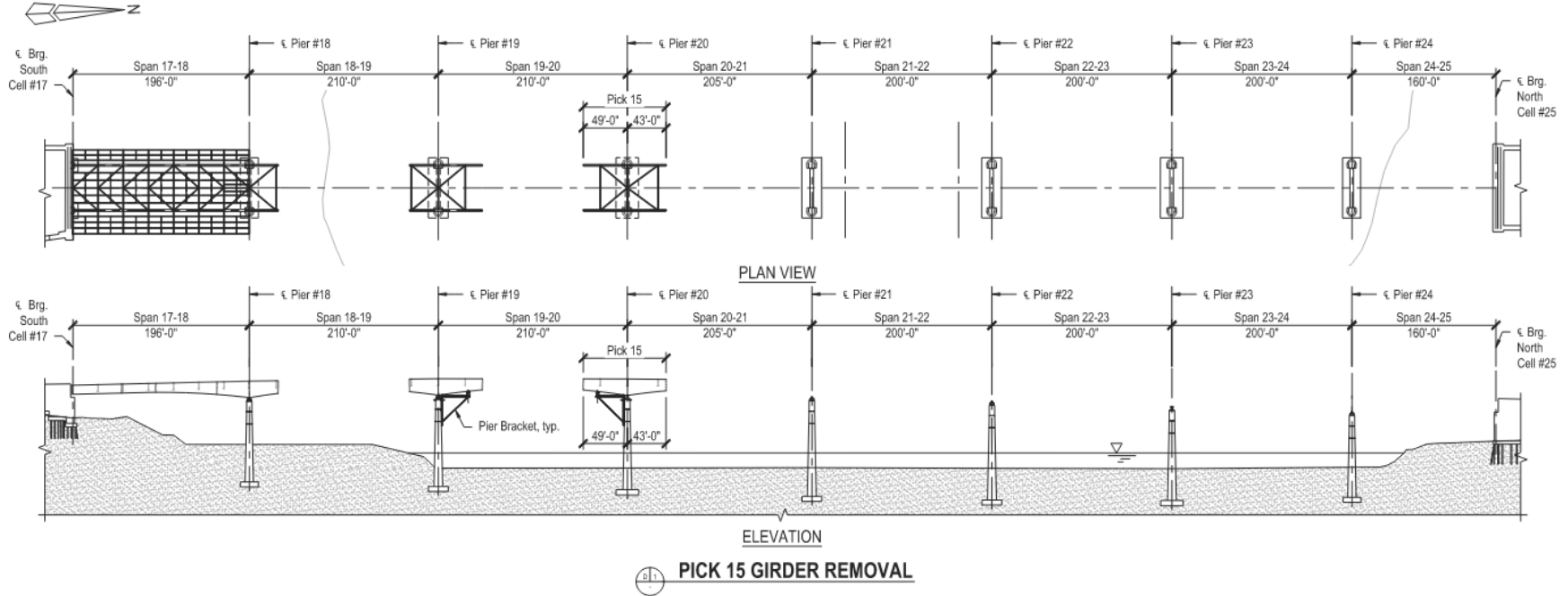

Girder Removal Stage 16

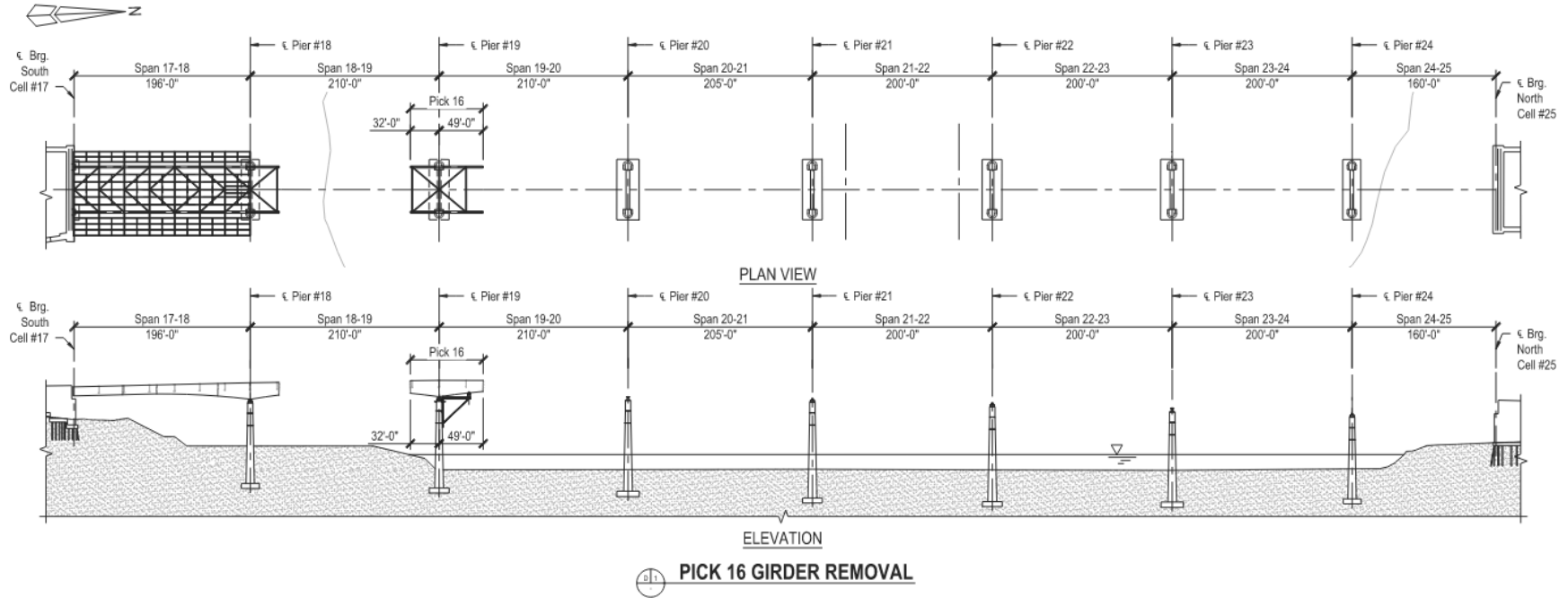

Girder Removal Stage 17

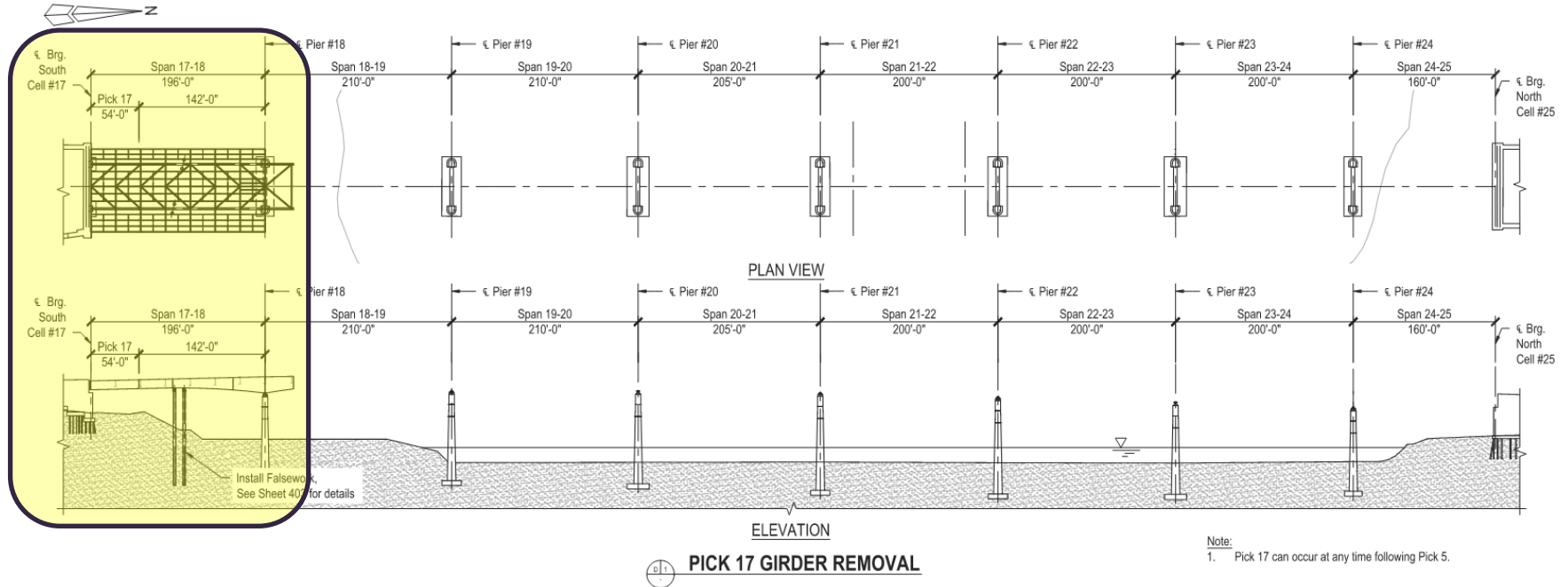

Falsework

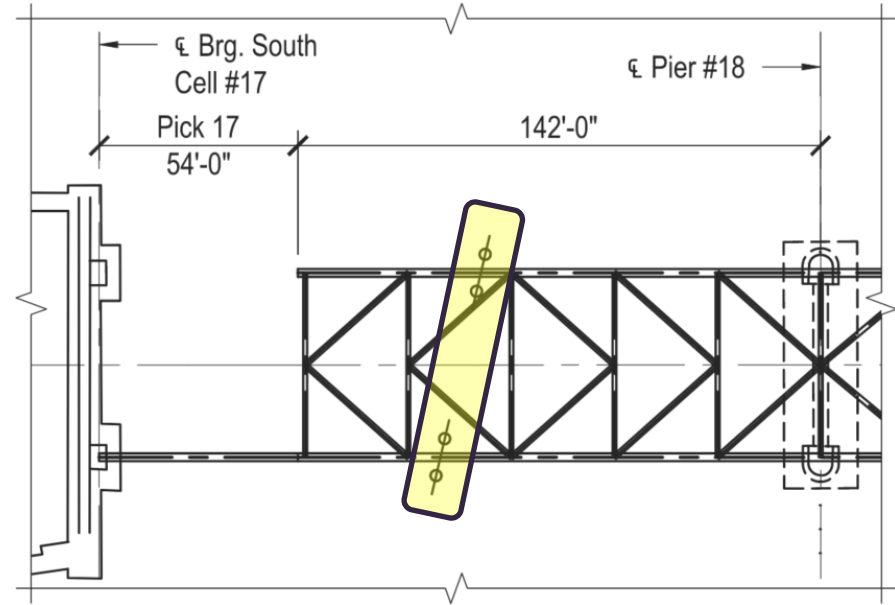
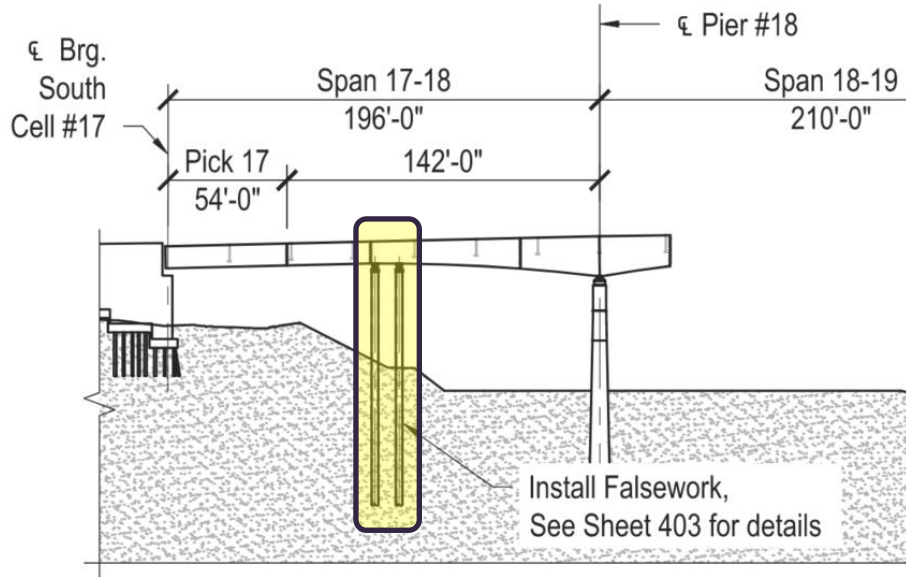

Falsework - Pile Sleeves



Falsework



Girder Removal Stage 18

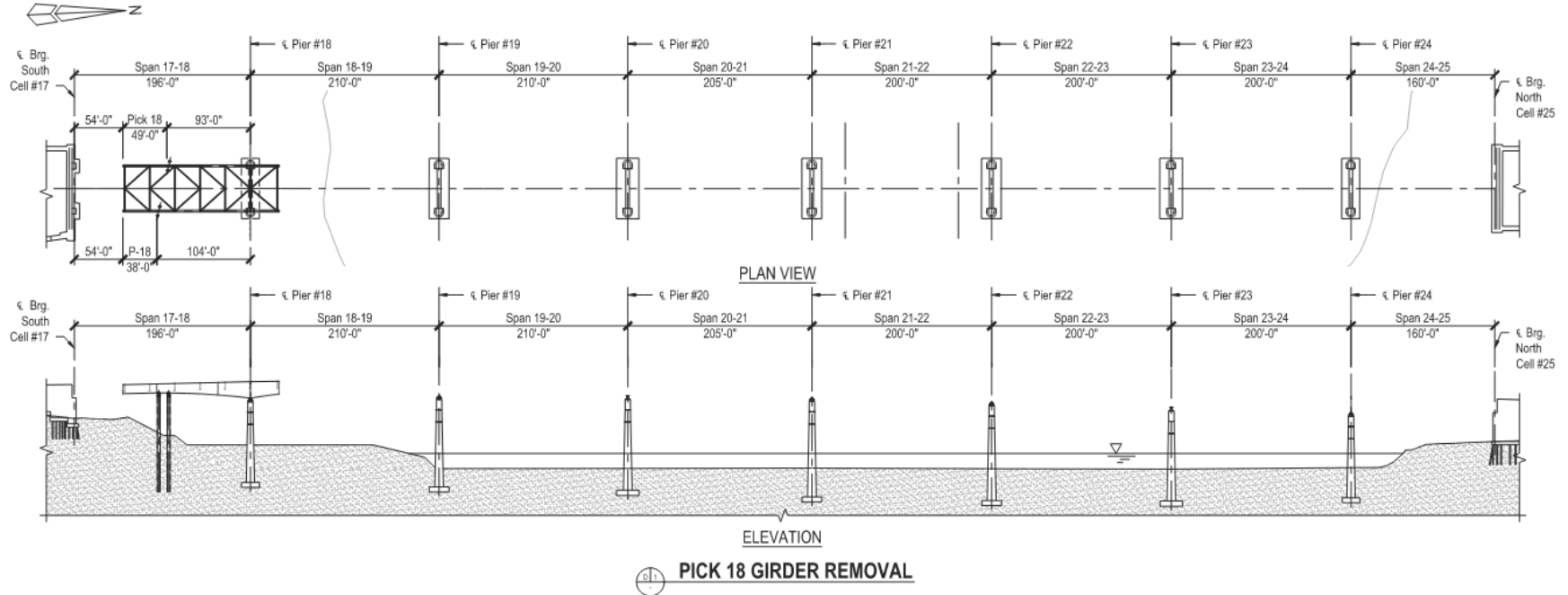

Girder Removal Stage 19

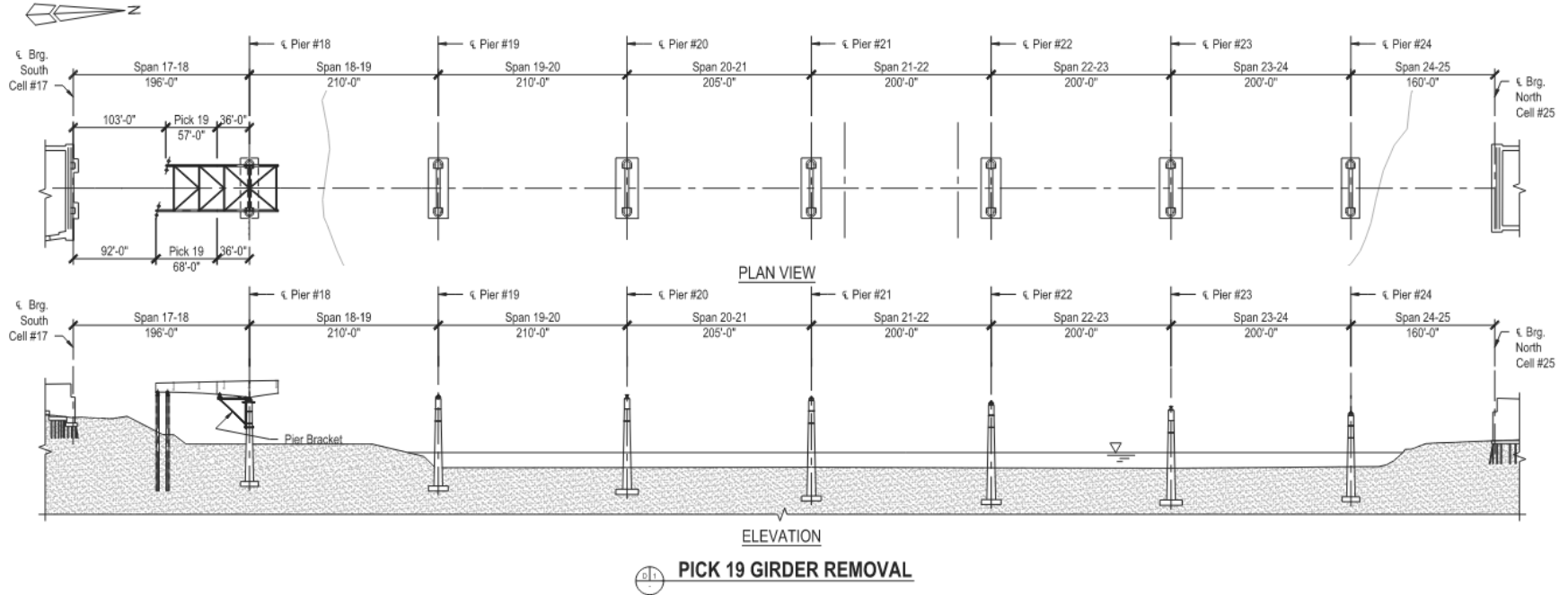

Custom Girder Clamps



Girder Removal Stage 20

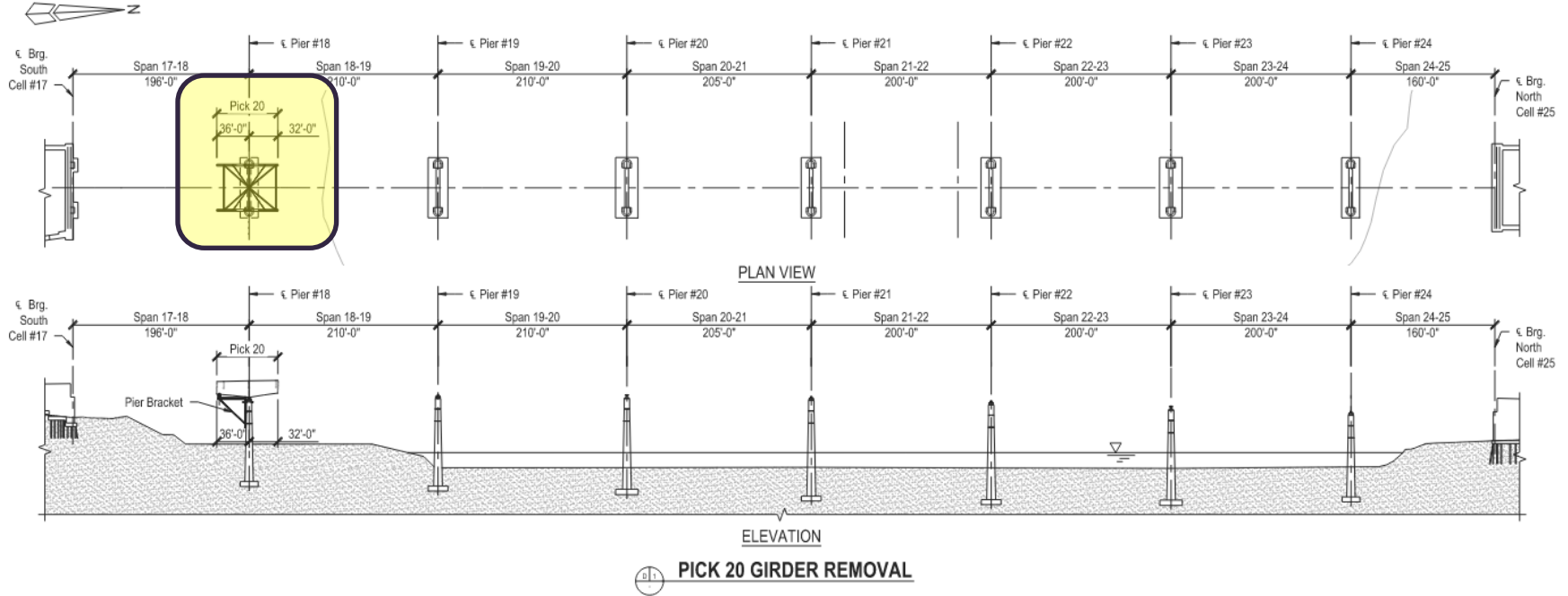

Final Girder Braces

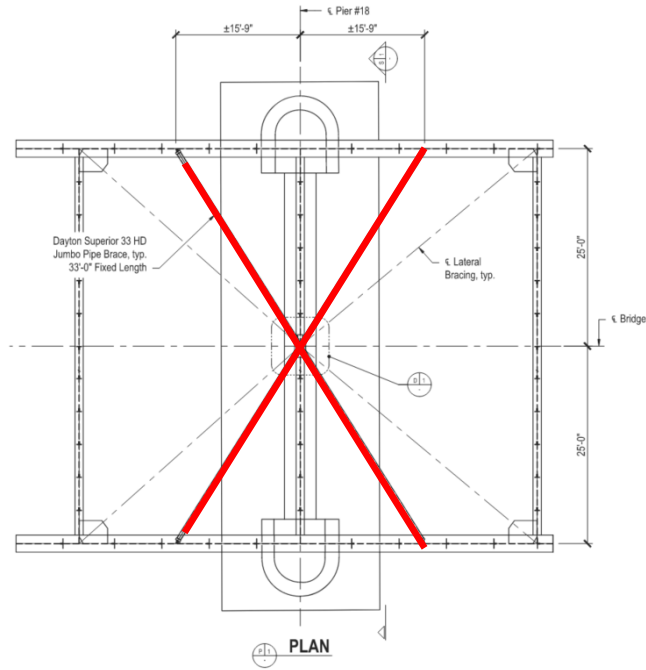

Presentation Outline

- Project Introduction
- Pre-Demolition Activities
- Deck & Misc Steel Removal
- Girder Removal
- **Current Status**

Current Status



Questions?



30 Crossing Construction. Panorama demolition old I-30 bridge at Pier 24, North Little Rock, Arkansas. October 25, 2022. ©David Hoge IMM03195-pano.ar

Photo Credit: David Hoge